

braid

**Outdoor**

braid

**Braid**

5

**Collezioni** *Collections*

**Maxim**

9

**Zoe**

37

**Tecla**

51

**Mood**

69

**Mahè**

83

**Melania**

95

**Metropolitan**

105

**Berenice**

139

**Cloe**

155

**Teodora**

179

**Leonia**

183

**Designers**

186

**Sezione tecnica** *Technical section*

191

**Cuscini** *Cushions*

221

**Tessuti & Materiali** *Fabrics & Materials*

231

# Braid

## Braid, ovvero l'arte dell'intreccio.

La storia comincia negli Anni '50, tre generazioni fa, quando Luigi Maurizi, maestro intrecciato di grande talento, apre a Mogliano nella regione Marche la sua bottega artigianale specializzata nella lavorazione del vimini: ceste e borsette di uso quotidiano. Forme e stili nascono dalla creatività del fondatore. Le sue mani corrono veloci tra i fili sottili delle fibre naturali e intrecciano pezzi unici molto apprezzati in tutto il mercato italiano.

Alla fine degli anni '70 Giuseppe, figlio di Luigi, entra in azienda e intuisce grazie alla sua visione, il grande potenziale del laboratorio paterno. Decide quindi di allargare la produzione al settore dell'arredamento. Nasce così il primo catalogo di prodotti per la casa: scrivanie, piccoli cabinet, divanetti, poltrone e tavolini, tutti in vimini, midollino e rattan intrecciati a mano, adatti ad un utilizzo indoor e outdoor.

La passione per le cose fatte ad arte è condivisa anche dai figli di Giuseppe che all'inizio degli anni '90 sono artefici dell'ulteriore evoluzione imprenditoriale del business di famiglia.





Dopo aver distribuito i prodotti di un'azienda di arredi per l'esterno in midollino sintetico, nel 2005 grazie al know-how acquisito, fondano Braid che in inglese significa, appunto, intreccio. Le nuove collezioni outdoor si affermano presso una clientela selezionata. Le fibre naturali sono sostituite con quelle sintetiche, apprezzate per la loro resistenza agli agenti atmosferici, la durevolezza, la praticità. Materiali di pregio quali il legno e l'alluminio vengono introdotti nelle collezioni per estendere l'offerta e sottolineare la versatilità della produzione.

La possibilità offerta ai clienti di personalizzare forme, dimensioni e colori diventa presto uno dei fattori di successo del brand.

La scelta di mantenere buona parte della produzione "MADE IN ITALY" esprime la volontà di valorizzare competenze e antiche tradizioni artigianali del territorio.

Nel 2013 alcuni componenti della famiglia Guzzini convinti delle potenzialità di espansione di Braid, entrano nell'azionariato, contribuendo così all'implementazione di una strategia di progressiva internazionalizzazione.

La trasformazione dell'azienda rispetto al laboratorio degli anni '50 è considerevole. I valori rimangono invece quelli di sempre: artigianalità, qualità, maestria nell'arte dell'intreccio che ancora oggi è fatto rigorosamente da mani sapienti.

### *Braid, or the art of weaving.*

*Its story starts in the 50's, three generations ago, in Mogliano a small town in the region of Marche, where Luigi Maurizi, a talented master caner, opens his workshop specialized in hand-crafted wicker products such as baskets and purses. His creativity gives birth to shapes and styles and his hands, smoothly flowing through the thin threads of natural fibers, weaves unique pieces, highly appreciated in the Italian market. At the end of the 70's, Giuseppe's son Luigi joins the company. Thanks to his forward-looking vision, he foresees the great potentiality in his paternal workshop and decides to broaden production to furniture, bringing to life the first home furnishing catalog presenting desks, small cabinets, sofas, armchairs and coffee tables made of hand-woven wicker, rush, or rattan, all suitable both for indoor and outdoor use.*

*This passion is passed down to and shared with his children, who at the beginning of the 90's take a step towards the evolution of their family-run business. In 2005, after distributing outdoor furniture made of synthetic rush for another company, thanks to their acquired know-how they found Braid, the English translation for the Italian word intreccio, that is to say, the result of weaving.*

*New outdoor collections start establishing themselves among a select clientele. Natural fibers are replaced by synthetic ones, more appreciated for their durability, ease of use, and resistance to weathering. Collections present new high-quality materials, such as wood and aluminum, showing an extended range of products and a certain versatility. The possibility to customize shapes, dimensions and colors soon becomes a success factor for the brand.*



*Their decision to keep most production made in Italy reveals their bond to the antique artisan traditions and skills of their territory.*

*In 2013 some members of Guzzini family, convinced of Braid's expansion potential, become stockholders of the company, contributing to its internationalization strategy.*

*From artisan workshop in the 50's to worldwide established business, the company has remarkably changed, yet preserving its authentic values of quality and craftsmanship.*



# Maxim

Design Carlo Colombo & Luciana Monticelli

Eleganza e pulizia di linee, a partire dall'incrocio a X che caratterizza la struttura in legno pregiato di tutti gli elementi della collezione. È Maxim, una linea completa di arredi ispirati al mondo della nautica e perfetti sia per spazi esterni sia per spazi interni. Il calore e la sensualità al tatto legno sono associati a raffinati dettagli in acciaio inox e dall'utilizzo del Batyline®, un tessuto in poliestere traspirante, straordinariamente resistente ad agenti atmosferici e all'usura del tempo.

*Elegance, purity of lines, and the distinctive X frame structure in fine wood characterize each item of the collection. This is Maxim: a set of furnishings inspired from nautical themes suitable both for indoors and outdoors. The sensuality and warmth of wood are perfectly matched with refined details in stainless steel and Batyline®, a breathable polyester fabric that is extremely resistant to tear, scratch, and atmospheric agents.*

100.002  
Sedia richiudibile  
Director chair





12



13

100.002  
**Sedia richiudibile**  
*Director chair*

100.012  
**Tavolo pranzo rettangolare**  
*Rectangular dining table*





14



15

100.007  
Tavolino d'appoggio  
Side table

100.008  
Tavolino d'appoggio grande  
Big side table

100.009  
Tavolino salotto  
Coffee table

100.001  
Sgabello  
Barstool



16

Maxim



17



100.006  
**Lettino**  
*Sun lounger*

100.007  
**Tavolino d'appoggio**  
*Side table*



20

100.004  
**Poltrona**  
*Armchair*

100.005  
**Divano 3 posti**  
*3-seater sofa*

100.009  
**Tavolino salotto**  
*Coffee table*

21





100.002  
**Sedia richiudibile**  
*Director chair*

100.008  
**Tavolino d'appoggio grande**  
*Big side table*



100.002  
**Sedia richiudibile**  
*Director chair*

100.010  
**Tavolo pranzo quadrato**  
*Square dining table*







30



31

100.006  
**Lettino**  
*Sun lounger*

100.007  
**Tavolino d'appoggio**  
*Side table*



32

100.004  
**Poltrona**  
*Armchair*

100.005  
**Divano 3 posti**  
*3-seater sofa*

100.009  
**Tavolino salotto**  
*Coffee table*



33





# Zoe

Design Braid Lab & Luciana Monticelli

Geometria essenziale, linee squadrate e contemporanee per la collezione Zoe. La struttura in alluminio verniciato a polvere ha una sezione sottile che accoglie i cuscini di seduta di divani e poltrona dalle dimensioni importanti. L'intreccio è in fibra piatta di polietilene Silver Dust dai riflessi cangianti che dona un piacevole effetto di profondità. La collezione comprende anche lettini alti e bassi e tavolini d'appoggio.

*Zoe collection focuses on a simple structure, squared and contemporary shapes. The powder-coated aluminum frame is provided with a thin cut holding large seating cushions for sofas and armchairs. The braid is made of flat Silver Dust polyethylene fiber and gives an enjoyable sense of depth thanks to its shimmering glares. The collection also includes high and low sun loungers and side tables.*



101.001  
**Poltrona**  
*Armchair*







42

101.005  
**Tavolino salotto**  
*Coffee table*



43



44

101.001  
**Poltrona**  
*Armchair*



45

101.008  
**Tavolino d'appoggio alto**  
*High side table*

101.009  
**Tavolino d'appoggio basso**  
*Low side table*



101.009  
Tavolino d'appoggio basso  
*Low side table*

101.006  
Lettino basso  
*Low sun lounger*

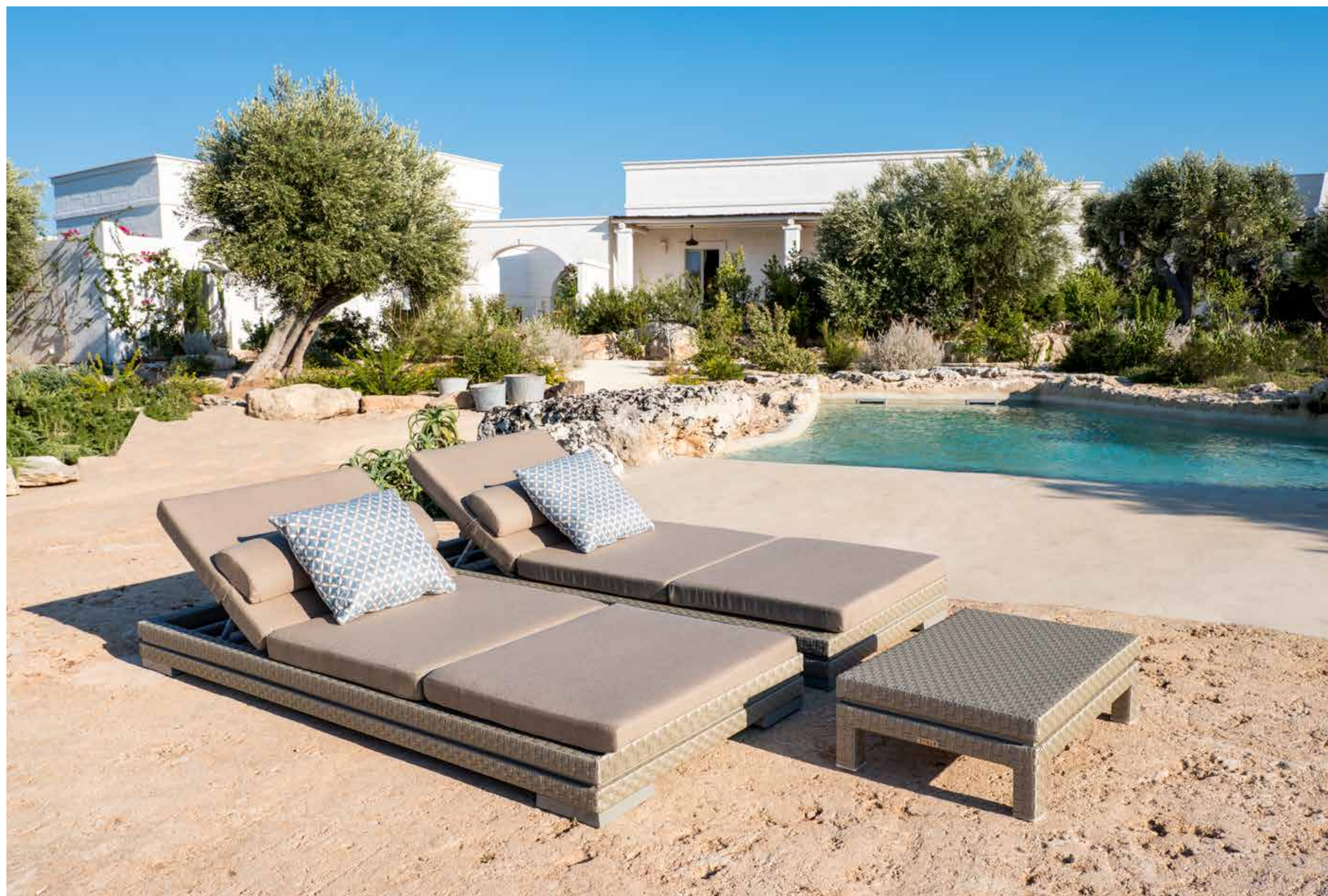

101.007  
**Lettino alto**  
*High sun lounger*





# Tecla

Design Braid Lab

Geometria trapezoidale per la collezione *Tecla collection shows trapezoidal shapes. The horizontal spaced-out wooden bars define the frame and lighten its volume. The structure of the armchair, of the 2 or 3-seater sofa and of the sun loungers is in epoxy-powder-coated aluminum. Tecla is available in two colorways, black and white. The side table is made of fine wood with a natural finish, as well as the wheels and the slats of the single and double sun loungers.*

102.001  
Poltrona  
Armchair







102.001  
**Poltrona**  
*Armchair*

102.003  
**Divano 3 posti**  
*3-seater sofa*

102.006  
**Tavolino d'appoggio**  
*Side table*

110.001  
**Lanterna grande**  
*Big lantern*

110.002  
**Lanterna media**  
*Medium lantern*

110.003  
**Lanterna piccola**  
*Small lantern*



102.001  
Poltrona  
Armchair

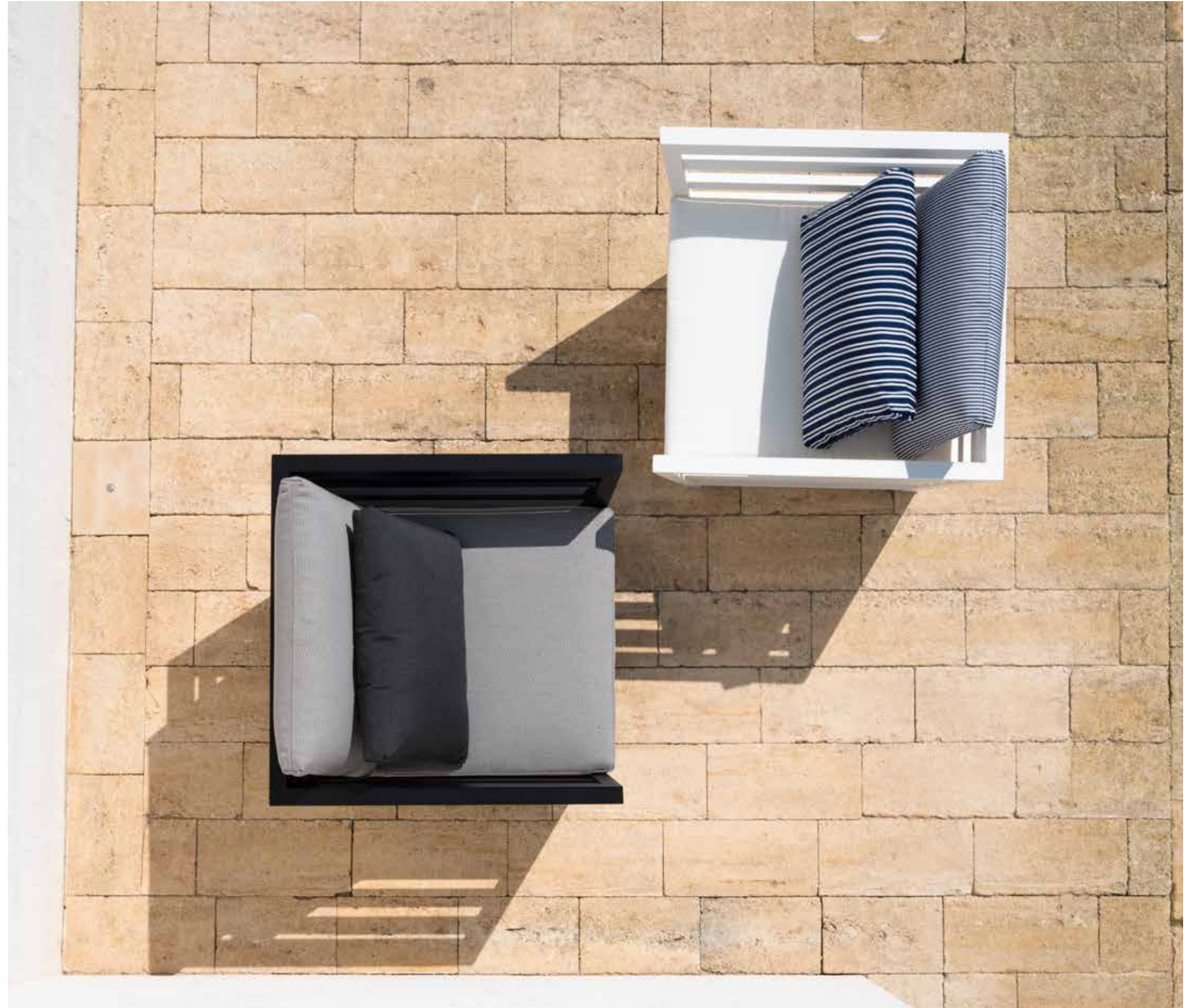



60



61

102.001  
**Poltrona**  
*Armchair*

102.002  
**Divano 2 posti**  
*2-seater sofa*

102.006  
**Tavolino d'appoggio**  
*Side table*



102.006  
Tavolino d'appoggio  
Side table

102.004  
Lettino  
Sun lounger





102.005  
**Lettino doppio**  
*Double sun lounger*

110.001  
**Lanterna grande**  
*Big lantern*

110.002  
**Lanterna media**  
*Medium lantern*



102.006  
Tavolino d'appoggio  
Side table





# Mood

Design Carlo Colombo

Design dalle linee curve e generose per Mood. Un evidente richiamo al comfort e al relax. I materiali utilizzati, alluminio verniciato a polvere per le strutture e fibra sintetica intrecciata per il rivestimento, garantiscono durata e inalterabilità nel tempo. Il prezioso motivo ad intreccio della fibra piatta Shimmer esalta la capacità artigianale e l'attenzione per i dettagli. La collezione comprende poltrone, divani a configurazione fissa e modulare, sedie, tavoli e tavolini e un lettino prendisole dotato di un pratico e discreto contenitore porta cuscini.

*A curvy design that recalls comfort and relax. Powder-coated aluminum frames and woven synthetic fibers guarantee durability and inalterability. The valuable woven pattern of Shimmer flat fiber enhances the artisan craftsmanship and attention to details. The collection consists of armchairs, regular and sectional sofas, dining chairs and tables and a sun lounger with a cushion storage.*



103.003  
Poltrona  
Armchair

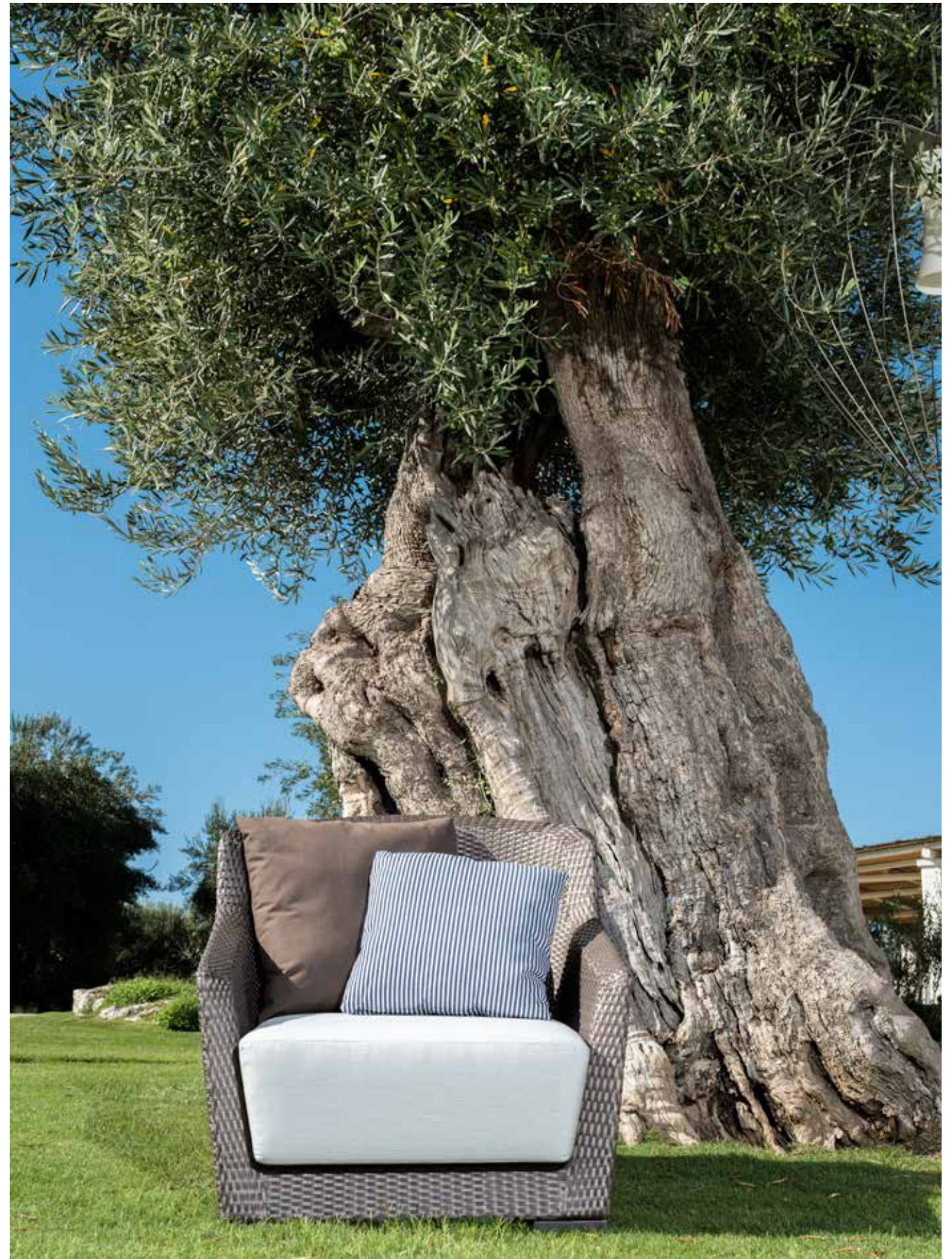



72



73

103.003

**Poltrona**  
*Armchair*

103.004

**Divano 2 posti**  
*2-seater sofa*





103.003  
**Poltrona**  
*Armchair*

103.006  
**Tavolino d'appoggio**  
*Side table*

103.013  
**Pouff**  
*Ottoman*



103.005  
**Lettino**  
*Sun lounger*

103.006  
**Tavolino d'appoggio**  
*Side table*





103.002  
**Poltroncina pranzo**  
*Dining armchair*

103.009  
**Tavolo pranzo rettangolare**  
*Rectangular dining table*





103.002  
**Poltroncina pranzo**  
*Dining armchair*

103.008  
**Tavolo pranzo quadrato**  
*Square dining table*





# Mahè

Design Angeletti - Ruzza

Forme pure, levigate e scultoree che esaltano comfort e versatilità. La collezione di sedute Mahè componibili a piacere è studiata per arredare sia gli spazi interni sia quelli esterni. La struttura in multistrato marino garantisce durata e resistenza agli agenti atmosferici. L'imbottitura è realizzata in gomma drenante e il rivestimento è con tessuti idrorepellenti della collezione Braid. Il rivestimento è disponibile anche in pelle dall'effetto vintage naturale trattata per l'utilizzo outdoor.

*A pure, smooth and sculptural style highlighting comfort and versatility. Mahe collection, with its modular components is perfect to furnish both outdoor and indoor spaces. The multiple layer marine plywood frame is a guarantee for duration and resistance to weathering. The padding is made of permeable rubber covered by waterproof fabrics taken from Braid collection. The covering is also available in natural vintage leather, treated for outdoor use.*

108.008  
**Lettino**  
*Sun lounger*



108.004  
**Terminale sinistro**  
*Left terminal*

108.009  
**Pouff**  
*Ottoman*

108.006  
**Dormeuse sinistra**  
*Left-arm chaise longue*







108.001  
**Elemento centrale**  
*Central section*

108.004  
**Terminale sinistro**  
*Left terminal*

108.008  
**Lettino**  
*Sun lounger*

108.009  
**Pouff**  
*Ottoman*

109.002  
**Tavolino d'appoggio**  
*Side table*



108.004  
**Terminale sinistro**  
*Left terminal*

108.006  
**Dormeuse sinistra**  
*Left-arm chaise longue*



108.004  
**Terminale sinistro**  
*Left terminal*

108.006  
**Dormeuse sinistra**  
*Left-arm chaise longue*

108.009  
**Pouff**  
*Ottoman*





# Melania

Design Luciana Monticelli

Proporzioni equilibrate, design formale e rotondità misurate. La collezione Melania richiama le atmosfere bon-tone e le conversazioni estive al riparo dalla canicola in città o in campagna. La fibra di polietilene Off White che si ispira al giacinto d'acqua è arrotolata su sé stessa e intrecciata sulla struttura in alluminio verniciato a polvere. La gamma di prodotti comprende un divanetto 2 posti, poltrona, poltroncina da pranzo, e lanterne.

*Balanced relationships, stylish design and sober roundedness. Melania collection recalls bon-ton atmospheres and summer conversations far from the midday heat either in the city or in the countryside. The Off White polyethylene fiber which borrows from the water hyacinth is wrapped up and braided on a powder-coated aluminum frame. The range of products includes a 2-seater sofa, an armchair, a dining armchair and lanterns.*

106.009  
**Lanterna piccola**  
*Small lantern*

106.010  
**Lanterna media**  
*Medium lantern*

106.011  
**Lanterna grande**  
*Big lantern*

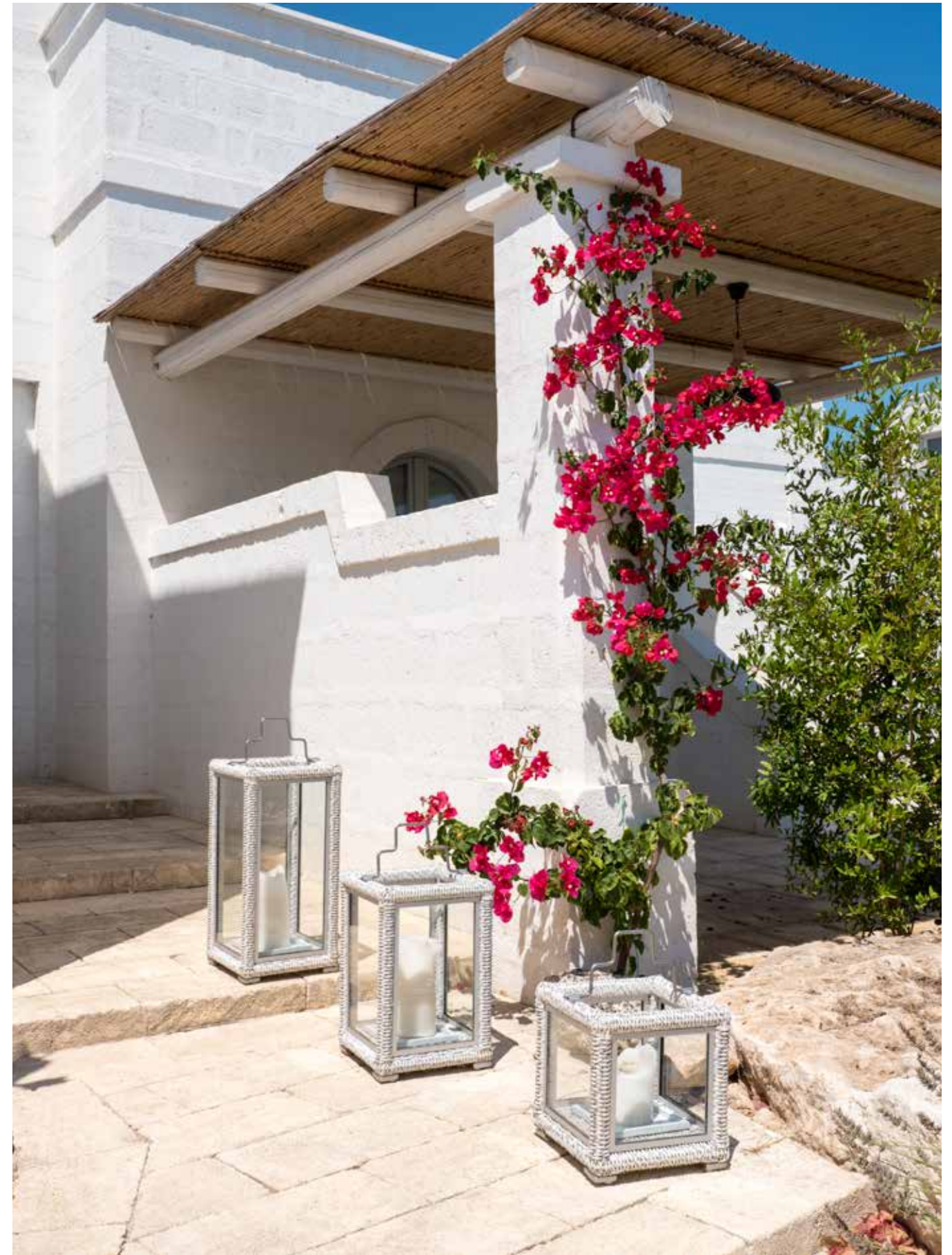

106.002  
**Poltrona**  
*Armchair*

106.001  
Poltroncina pranzo  
Dining armchair

109.005  
Tavolo rotondo pranzo  
Round dining table



106.002  
**Poltrona**  
*Armchair*

100



101

106.001  
**Poltroncina pranzo**  
*Dining armchair*

109.004  
**Tavolo pranzo quadrato**  
*Square dining table*



102

106.002  
Poltrona  
Armchair



103



# Metropolitan

Design Carlo Colombo

105

L'estetica ricercata di Metropolitan si distingue per un'alternanza di vuoti e di pieni che ne alleggerisce la struttura facendola fluttuare nello spazio. Il telaio in alluminio verniciato a polveri epossidiche (con caratteristiche antiurto e antigraffio) è disponibile nei colori white, taupe e gold. Le cinghie in poliestere a vista sono in abbinamento alla struttura nelle colorazioni Ice, taupe e black. L'ampia gamma di sedute è disponibile con struttura a semicerchio o lineare. Quest'ultima offre la possibilità di affiancare i moduli per creare infinite configurazioni. Oltre a divani, poltrone e sedie, completano la collezione tavoli, tavolini e lettini prendisole.

*The polished look of Metropolitan shines for its alternation of solids and voids that gives the structure a sense of lightness. Its frame made of epoxy-powder-coated aluminum (with scratch-proof and shockproof properties) is available in white, taupe, and gold color. Polyester bands are coordinated with the frame and available in ice, taupe, and gold color. The wide range of seats and backrests come with a semi-circular or linear structure. The linear choice gives the possibility to create infinite modular configurations. In addition to sofas, armchairs and chairs, the collection includes tables, coffee tables, and sun loungers.*



104.004  
**Divano 2 posti**  
*2-seater sofa*

104.007  
**Tavolino salotto**  
*Coffee table*

104.009  
**Angolo sinistro**  
*Left corner*

104.011  
**Elemento centrale**  
*Central section*

104.012  
**Pouff**  
*Ottoman*

110.001  
**Lanterna grande**  
*Big lantern*

110.002  
**Lanterna media**  
*Medium lantern*

110.003  
**Lanterna piccola**  
*Small lantern*





108

104.007  
**Tavolino salotto**  
*Coffee table*

104.009  
**Angolo sinistro**  
*Left corner*

104.011  
**Elemento centrale**  
*Central section*

104.012  
**Pouff**  
*Ottoman*



109



104.007  
**Tavolino salotto**  
*Coffee table*

104.009  
**Angolo sinistro**  
*Left corner*

104.011  
**Elemento centrale**  
*Central section*

104.012  
**Pouff**  
*Ottoman*





112

104.002  
**Poltroncina pranzo**  
*Dining armchair*

104.008  
**Tavolo pranzo allungabile**  
*Extendable dining table*



113

104.004  
Divano 2 posti  
2-seater sofa





116



117

104.003

**Poltrona**  
*Armchair*

104.004

**Divano 2 posti**  
*2-seater sofa*



104.003  
**Poltrona**  
*Armchair*

104.006  
**Tavolino d'appoggio**  
*Side table*

104.007  
**Tavolino salotto**  
*Coffee table*

104.009  
**Angolo sinistro**  
*Left corner*

104.010  
**Angolo destro**  
*Right corner*

104.011  
**Elemento centrale**  
*Central section*

104.012  
**Pouff**  
*Ottoman*

120



121



104.005  
**Lettino**  
*Sun lounger*



104.005  
**Lettino**  
*Sun lounger*

104.006  
**Tavolino d'appoggio**  
*Side table*



104.001  
**Sedia**  
*Dining chair*

104.002  
**Poltroncina pranzo**  
*Dining armchair*

104.008  
**Tavolo pranzo allungabile**  
*Extendable dining table*



126



127



104.004  
**Divano 2 posti**  
*2-seater sofa*

104.007  
**Tavolino salotto**  
*Coffee table*



104.007  
**Tavolino salotto**  
*Coffee table*

104.009  
**Angolo sinistro**  
*Left corner*

104.010  
**Angolo destro**  
*Right corner*

104.011  
**Elemento centrale**  
*Central section*





104.007  
**Tavolino salotto**  
*Coffee table*

104.009  
**Angolo sinistro**  
*Left corner*

104.011  
**Elemento centrale**  
*Central section*

104.012  
**Pouff**  
*Ottoman*



104.007  
**Tavolino salotto**  
*Coffee table*

104.009  
**Angolo sinistro**  
*Left corner*

104.010  
**Angolo destro**  
*Right corner*

104.011  
**Elemento centrale**  
*Central section*

104.012  
**Pouff**  
*Ottoman*



134



135

104.001  
**Sedia**  
*Dining chair*

104.002  
**Poltroncina pranzo**  
*Dining armchair*

104.008  
**Tavolo pranzo allungabile**  
*Extendable dining table*

104.005  
**Lettino**  
*Sun lounger*





# Berenice

Design Archivio Braid

139

Un pezzo storico evergreen ridisegnato in chiave contemporanea. Berenice è un rifugio accogliente, dalle linee squadrate e dalle proporzioni generose. Le sedute profonde e le cuscinate ampie assicurano grande comfort. Il rigore delle forme è bilanciato dalla fibra sintetica dalle caratteristiche simili al "giacinto d'acqua" dalla texture morbida e naturale lavorata con un singolare effetto tricot. La struttura degli elementi della collezione, poltrona, divano tre posti e tavolini, è in alluminio verniciato a polvere.

*Renovation of a Braid classic, Berenice is a cozy haven made of squared lines and generous proportions that, thanks to deep seats and wide cushions, ensure great comfort. The simplicity of its shapes is mitigated by the synthetic fiber, recalling water hyacinth characteristics, and by the peculiar tricot-style soft and natural texture. Each item of this collection - armchair, 3-seater sofa and coffee tables - has a powder-coated structure.*

140



141

107.001  
**Poltrona**  
*Armchair*



142



107.001

**Poltrona**  
*Armchair*

107.003

**Tavolino d'appoggio**  
*Side table*



143



107.002  
**Divano 3 posti**  
*3-seater sofa*

104.007  
**Tavolino salotto**  
*Coffee table*

109.002  
**Tavolino d'appoggio rotondo**  
*Round side table*





146



147

107.001

**Poltrona**  
*Armchair*

107.002

**Divano 3 posti**  
*3-seater sofa*

107.003

**Tavolino d'appoggio**  
*Side table*



150



G107.002  
Cover divano  
Sofa cover

104.007  
Tavolino salotto  
Coffee table

151





G107.001  
Cover poltrona  
Armchair cover

G107.002  
Cover divano  
Sofa cover

104.007  
Tavolino salotto  
Coffee table



# Cloe

Design Archivio Braid

155

Cloe con le sue linee morbide e le sue rotondità rassicuranti è come un nido invitante che accoglie e abbraccia. Una collezione ricca di elementi per tutti gli ambienti outdoor, dall'area living, al pranzo e al bordo piscina. Lettini singoli e doppi o a conchiglia, una vera e propria alcova nella quale indugiare. Struttura in alluminio verniciato a polvere e intreccio realizzato con fibra Natural a sezione tonda dal caratteristico effetto legno anche nel tatto leggermente irregolare.

*Comforting balance and soft lines remake the house into a cozy home. Cloe collection is rich in components for outdoor spaces, from living areas to dining spaces and pool-side ones. Single, and double sun loungers and shell daybeds recall a real inviting love nest. The collection shines for its powder-coated aluminum frame and the natural round cross-section fiber which make the braid produce the characteristic woodcarving effect both in the look and in the slightly irregular touch.*

105.003  
Poltrona  
Armchair

Cloe



156



157





105.010  
**Tavolino d'appoggio**  
*Side table*

105.011  
**Tavolino salotto rettangolare**  
*Rectangular coffee table*



160

161

**105.003****Poltrona***Armchair***105.004****Divano 3 posti***3-seater sofa***105.011****Tavolino salotto rettangolare***Rectangular coffee table*



105.005  
**Divano componibile circolare**  
*Circular sectional sofa*





166



105.001  
**Sedia**  
*Dining chair*

167



105.001  
**Sedia**  
*Dining chair*

105.013  
**Tavolo pranzo quadrato**  
*Square dining table*

105.001

**Sedia**

*Dining chair*

105.013

**Tavolo pranzo quadrato**

*Square dining table*



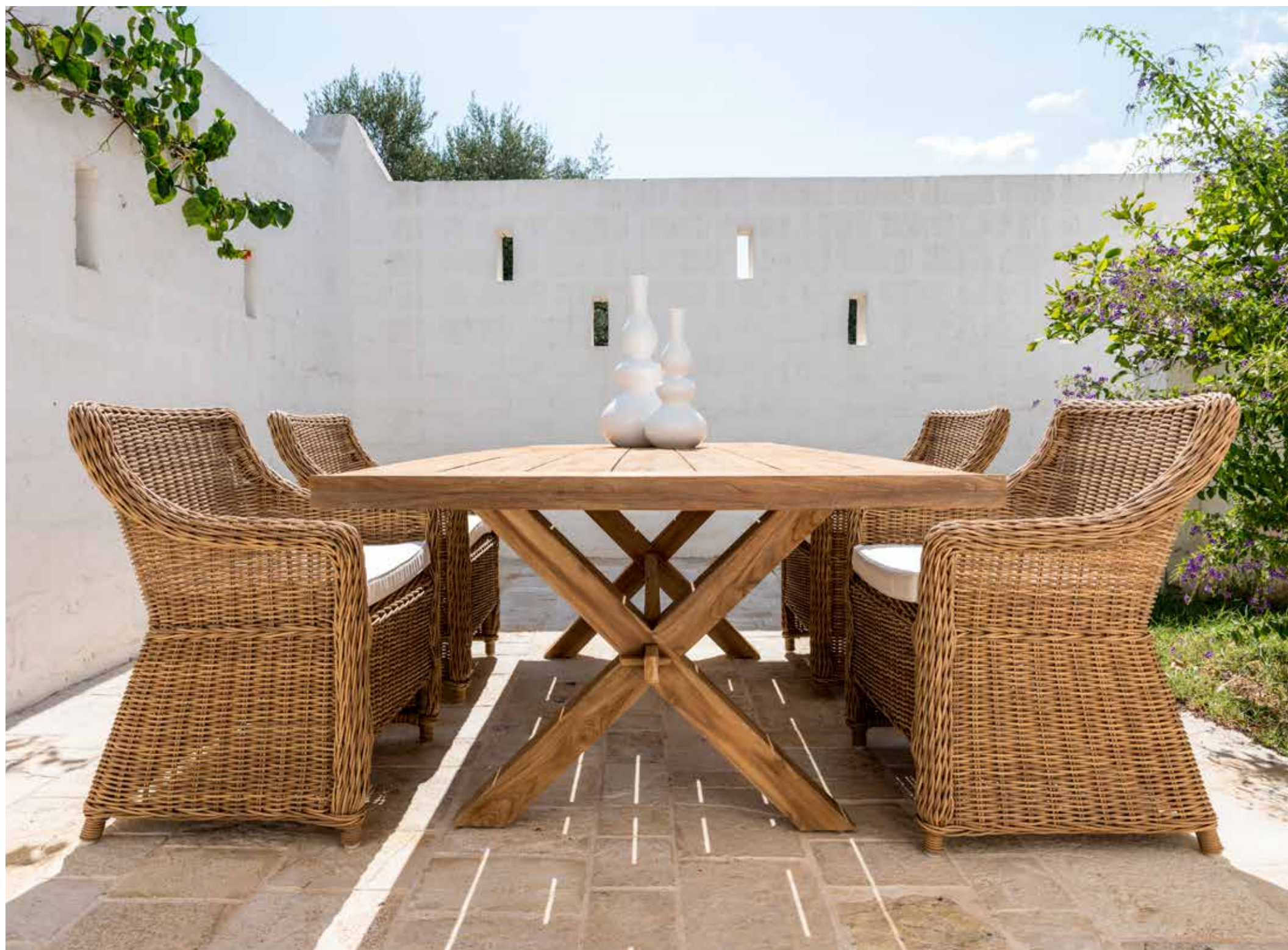

170



171

105.002  
**Poltroncina pranzo**  
*Dining armchair*

105.015  
**Tavolo in legno rettangolare**  
*Rectangular wooden dining table*



172



173

105.006  
**Lettino singolo**  
*Single sun lounger*



105.007  
Lettino doppio  
Double sun lounger





176



177

105.008  
**Conchiglia**  
*Shell daybed*

105.009  
**Pouff**  
*Ottoman*



# Teodora

Design Braid Lab

Minimalismo e funzionalità armonicamente bilanciati nella serie di tavoli e tavolini da appoggio Teodora. Il piano in alluminio e il basamento in acciaio che garantisce la massima stabilità, sono disponibili in sei finiture diverse: taupe, champagne, white, black, grey, gold. I tavoli da pranzo di dimensioni contenute hanno il piano tondo oppure quadrato. I tavolini d'appoggio sono disponibili nella versione quadrata, tonda oppure ovale. Tutti perfetti per uso outdoor e indoor.

*The keywords for Teodora tables and coffee tables are "well-balanced minimalism and functionality". The aluminum surface and the steel base providing maximum stability are available in six different finishes: taupe, champagne, white, black, grey and gold. The midsize dining tables are available in a round or square top surface, while for the coffee tables the range varies from round to square and oval shape. All of them are suitable for outdoor and indoor use.*

180



109.002  
**Tavolino d'appoggio rotondo**  
*Round side table*

109.003  
**Tavolino da fumo ovale**  
*Oval side table*

181

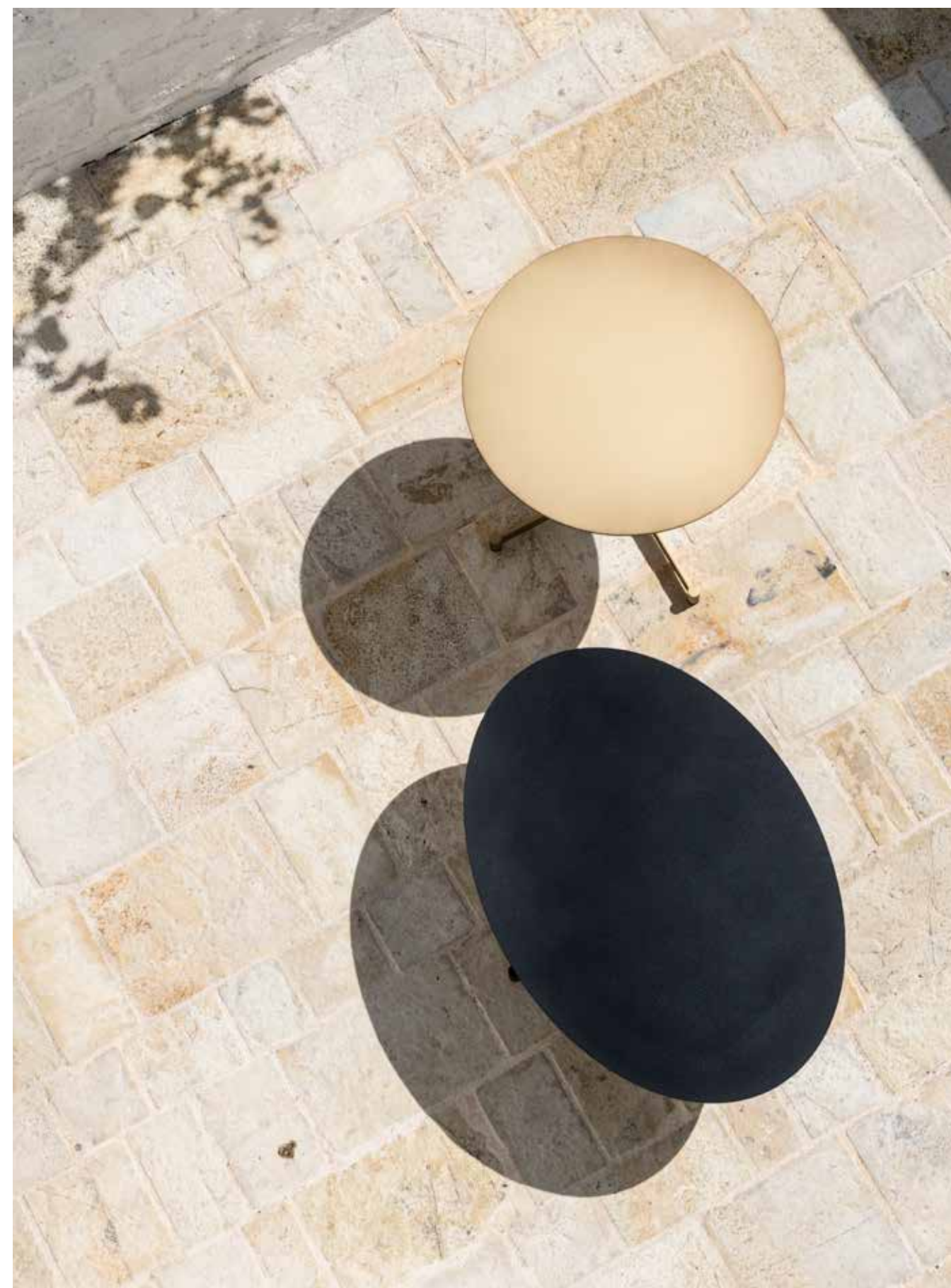



# Leonia

Design Braid Lab

Una collezione di lanterne per illuminare e decorare spazi aperti e chiusi. Disponibili in tre altezze differenti da abbinare liberamente per creare affascinanti paesaggi di luce. La struttura è in metallo verniciato in finitura black opaca o gold con un elegante effetto anticato realizzato a mano. Le pareti sono in vetro trasparente. Il manico circolare posto sull'estremità superiore delle lanterne può essere in radice di bambù naturale o verniciato nero lucido, oppure in metallo dello stesso colore della lanterna.

*Leonia is a collection of lanterns to light up and adorn outdoor and indoor spaces. It is available in three different heights which can be combined to create charming lighting effects. The frame is made of a painted metal in a matt black or gold finishes, completed by a handmade antique look. The sides are made of clear glass. The round handle on top of the lantern is available either in natural bamboo root, or painted in shiny black, or in metal matching the color of the lantern.*



110.001  
**Lanterna grande**  
*Big lantern*

110.002  
**Lanterna media**  
*Medium lantern*

110.003  
**Lanterna piccola**  
*Small lantern*



## Braid Lab

Braid Lab è l'atelier creativo creato nel 2005 e subito diventato il fulcro innovativo dell'azienda. Ricerca estetica, sviluppo di prodotti e selezione di materie prime di alta qualità sono le principali aree di sua competenza.

Il metodo di lavoro è rigoroso. Dopo un attento studio delle tendenze stilistiche e delle esigenze commerciali il Braid Lab definisce il brief del progetto, che traccia le linee guida della nuova collezione. Da quel momento il designer libera la sua creatività e parte con la progettazione.

Schizzi e disegni tecnici dettagliati, prototipi in scala 1:1, test effettuati su materiali, lavorazioni e finiture diverse, aggiustamenti di dimensioni e forme, prove di resistenza e messa a punto finale sono le tappe del protocollo di sviluppo dei prodotti del Braid Lab.

Solo dopo avere perfezionato il prodotto in ciascuna di queste fasi, nel rispetto degli standard qualitativi dell'azienda, si procede con la produzione e il lancio delle collezioni sui mercati italiani e internazionali.

Nell'archivio del Braid Lab insieme a disegni, schizzi, campioni, prototipi sono custoditi conoscenze, saper fare, capacità, testimonianze di sogni realizzati e da realizzare, oltre a tutti i materiali che raccontano 60 anni di storia aziendale. Gusto contemporaneo, lavorazioni artigianali, finiture ricercate e materiali pregiati della migliore qualità sono da sempre il fil rouge di tutta la produzione Braid.

*Braid Lab is a creative atelier which was founded in 2005 and quickly became the company cornerstone as regards innovation. Its main areas of expertise are aesthetical research, product development and high-quality raw materials selection.*

*Its working method is meticulous. After a proper study of stylistic trends and commercial needs, Braid Lab defines the project brief, which creates guidelines for the new collection. From that moment on, the designer sets his imagination free and the planning begins.*

*Braid Lab products development process consists of the following stages: sketches and detailed designs, 1:1 scale prototypes, tests made on raw materials, different manufacturing and finishes, changes in sizes and shapes, strength tests and final development.*

*Once the best possible result is obtained in each phase, according to the quality standards of the company, production is carried on and launched into the Italian and international markets.*

*Braid Lab knowledge consists of detailed designs, sketches, samples and prototypes as well as know-how, craftsmanship, talent, fulfilled wishes and long-cherished dreams, together with all the materials that featured a 60-year tradition.*

*Contemporary style, handmade production, refined finishes and best-quality selected materials have always been the silver thread of the whole Braid collection.*



## Carlo Colombo

Carlo Colombo è ritenuto tra i più importanti architetti e designer italiani. Fin da subito disegna per brand top level. Da quel momento colleziona centinaia di collaborazioni con i più importanti marchi del design Made in Italy: Antonio Lupi, Arflex, Artemide, Cappellini, De Padova, Flou, Flexform, iGuzzini, Moroso, Poliform, Poltrona Frau, Teuco, Varenna, Zanotta, solo per citarne alcuni.

Oltre al disegno di prodotti di arredo e al design, Colombo si occupa per le aziende di strategia e di marketing, elabora progetti grafici e cura mostre, lavora come consulente e come direttore artistico. L'attività progettuale, inizialmente concentrata sul design e la progettazione di interni, si estende progressivamente anche al settore delle costruzioni, in Italia e all'estero. Nel 2004 l'architetto vince il titolo di Designer dell'anno; nel 2009 vince un concorso internazionale per la progettazione di due torri polifunzionali ad Abu Dhabi e dal 2011 insegna progettazione presso la De Tao Masters Academy di Beijing, in Cina. Tra i molti riconoscimenti, basti ricordare nel 2005, 2008, 2010, 2011 l'Elle Decor International Design Award, nel 2009 il Good Design Award dell'European Centre for Architecture Art Design e The Chicago Athenaeum, nel 2012 vince il Red Dot Design Award e nel 2014 il "Best of the Best" del Red Dot Design Award, l'Interior Innovation Award e l'iF design award con Teuco. Oggi lo studio si occupa di progettazione su grande scala in tutto il mondo, dal design all'interior e all'architettura.

*Carlo Colombo is considered one of the most important Italian architects and designers. He started his career right away with designing for top level brands. From this moment he collects hundreds of collaborations with the most important brands of Made in Italy design, like Antonio Lupi, Arflex, Artemide, Cappellini, De Padova, Flou, Flexform, iGuzzini, Moroso, Poliform, Poltrona Frau, Teuco, Varenna, Zanotta, just to mention some.*

*Besides designing furnishings, Colombo also takes care of marketing and strategies for the companies, develops graphic projects and curates exhibitions, works as a consultant and art director. The work that was initially concentrated on design, extends progressively also in the field of constructions in Italy and abroad. In 2004 the architect is awarded as designer of the year; in 2009 he wins an international competition for designing two multifunctional towers in Abu Dhabi and from 2011 he has been teaching design at the De Dao Masters Academy of Beijing in China. Among his main achievements, the Elle Décor International Design Award in 2005, 2008, 2010, 2011, the Good Design Award of the European Center for Architecture Art Design and the Chicago Athenaeum in 2009. In 2012 he wins the Red Dot Design Award, in 2014 the "Best of the Best" Red Dot Design Award, the Interior Innovation Award and the iF design award with Teuco. Today the studio deals with large-scale projects all over the world, from design to interior as well as architecture.*



### Angeletti - Ruzza

Entrambi progettisti, laureati in Industrial Design all'I.S.I.A di Roma, Silvana Angeletti e Daniele Ruzza, compagni e partner nella vita e nella professione, aprono a Rieti il loro studio di design nel febbraio del 1994.

Dal 2010, svolgono attività di docenza presso lo IED di Roma.

Come Angeletti Ruzza Design, hanno partecipato e sono stati premiati e segnalati a numerose competizioni internazionali di design, ed hanno collaborato - sperimentando e curiosando in diversi territori di ricerca - con alcune fra le più importanti realtà industriali italiane, nei settori dell'arredobagno, dell'illuminazione, dell'arredamento, dei complementi d'arredo e nell'oggettistica per la tavola; hanno realizzato progetti di interior design per hotel e strutture ricettive. Alcuni loro prodotti fanno parte della collezione permanente del Chicago Athenaeum Museum. Art director di MY HOME COLLECTION dal 2016.

Sono stati direttori artistici per Azzurra (dal 2007 al 2014) e per GSI (dal 2002 al 2006).

*Silvana Angeletti and Daniele Ruzza are both architects and Industrial design graduates from I.S.I.A. in Rome. They are partners in life and in work and their design studio was launched in Rieti in 1994.*

*They have been teaching at the IED in Rome since 2010.*

*The studio Angeletti Ruzza Design participated in several international competitions, where Silvana and Daniele distinguished themselves and were awarded. They took an interest in many research fields and collaborated with some of the most important Italian industries for bath furnishings, lighting systems, interior design, complement furniture and table novelties. They also implemented interior design projects for hotels and tourist accommodations; some of their products are part of the Chicago Athenaeum Museum permanent collection.*

*In 2016 they were appointed as art directors of MY HOME COLLECTION.*

*They were art directors for Azzurra from 2007 to 2014 and they played the same role for GSI from 2002 to 2006.*



### Luciana Monticelli

Ogni sua collezione per Braid è frutto di un'accurata ricerca estetica e stilistica che coniuga le esigenze di lusso e ricercatezza a quelle di comfort, mantenendo sempre un carattere di unicità nella qualità e nel design d'avanguardia. L'eleganza senza tempo inserita in atmosfere di inconfondibile raffinatezza contraddistingue da sempre il tratto distintivo di Luciana Monticelli e si inserisce con grande coerenza nella produzione di Braid.

*Every collection she designs for Braid is the result of an accurate stylistic and aesthetic research which combines the need for luxury and attention to details together with comfort, always keeping a certain distinctiveness in quality and avant-garde design. The timeless elegance is inserted in a uniquely refined environment and is a lifelong sign of Luciana Monticelli's hallmark, perfectly suiting Braid production.*



# Sezione tecnica

## *Technical section*



**Berenice**

**Colori disponibili**  
*Available colors*



Euro Ash

**Berenice Cover**



**G107.001**  
**Cover Poltrona Armchair cover**



**G107.002**  
**Cover Divano 3 Posti 3-seater sofa cover**

192



**107.001**  
**Poltrona Armchair**



**107.002**  
**Divano 3 Posti 3-seater sofa**



**CB107.000**  
**Cuscino Cushion**



**CS107.000**  
**Cuscino Cushion**

193

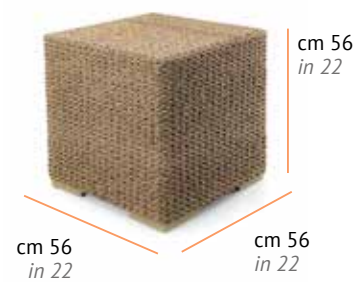

**107.003**  
**Tavolino d'appoggio Side table**

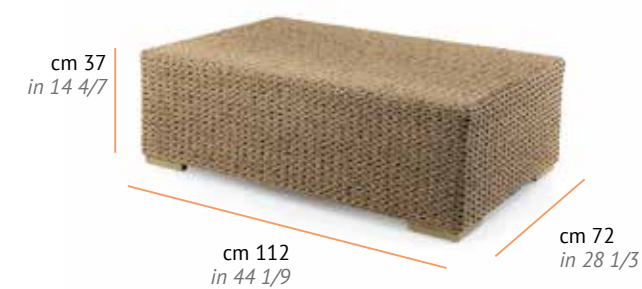

**107.004**  
**Tavolino salotto Coffee table**

**Colori disponibili**  
Available colors



Natural

194



**105.001**  
Sedia Dining chair



**105.002**  
Poltroncina pranzo Dining armchair



**105.003**  
Poltrona Armchair



**105.004**  
Divano 3 Posti 3-seater sofa



**105.005**  
Divano componibile circolare Circular sectional sofa



**105.006**  
Lettino singolo Single sun lounger



**105.007**  
Lettino doppio Double sun lounger



**105.008**  
Conchiglia Shell daybed

195



**105.009**  
Pouff Ottoman



**105.010**  
Tavolino d'appoggio Side table



105.011  
Tavolino salotto rettangolare *Rectangular coffee table*



105.012  
Tavolino salotto quadrato *Square coffee table*



105.013  
Tavolo pranzo quadrato *Square dining table*



105.014  
Tavolo pranzo rettangolare *Rectangular dining table*



105.015  
Tavolo pranzo rettangolare legno  
*Rectangular wooden dining table*



108.001  
Elemento centrale *Central section*

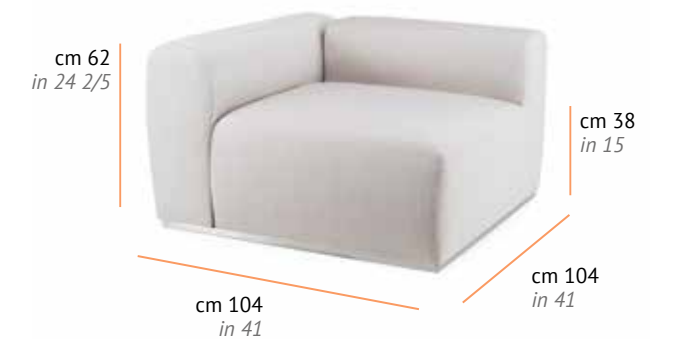

108.002  
Elemento angolare *Corner section*



108.004  
Terminale sinistro *Left terminal*



108.005  
Terminale destro *Right terminal*



108.006  
Dormeuse sinistra *Left-arm chaise longue*



108.007  
Dormeuse destra *Right-arm chaise longue*

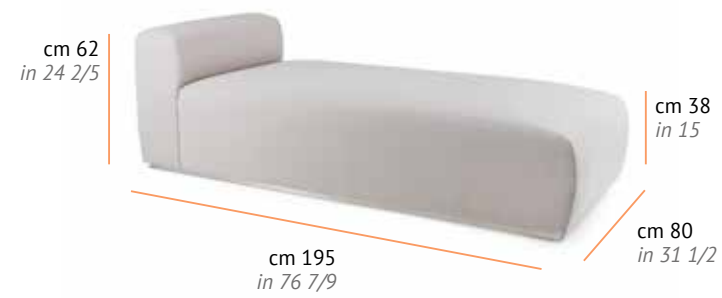

**Colori disponibili**  
Available colors



Natural Wood



Glossy Wood

La componentistica è in inox lucido.  
Metal components are in glossy stainless steel.

108.008  
**Lettino Sun lounge/chaise longue section**

108.009  
**Pouff Ottoman**



FL108.008  
**Copripiedi Sun lounge/chaise longue protection cover**

PT108.008  
**Cuscino lettino Sun lounge/chaise longue cushion**

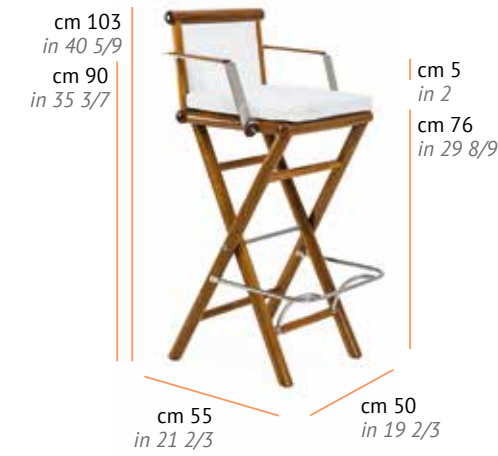

100.001  
**Sgabello Barstool**

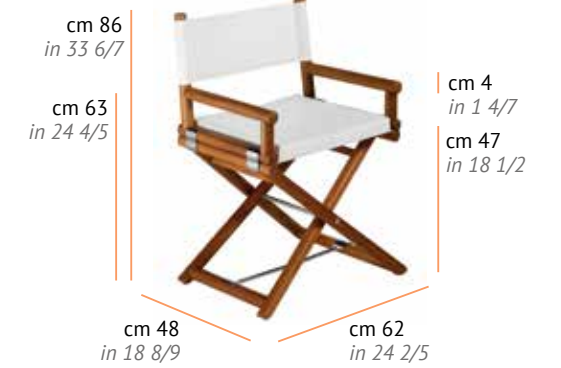

100.002  
**Sedia richiudibile Director chair**



100.003  
**Pouff Ottoman**



100.004  
**Poltrona Armchair**



100.005  
Divano 3 Posti 3-seater sofa



100.006  
Lettino Sun lounger



100.011  
Tavolo pranzo rotondo Round dining table



100.012  
Tavolo pranzo rettangolare Rectangular dining table



100.007  
Tavolino d'appoggio Side table



100.008  
Tavolino d'appoggio grande Big side table



100.009  
Tavolino salotto Coffee table



100.010  
Tavolo pranzo quadrato Square dining table

Colori disponibili  
Available colors



Matt black Wood

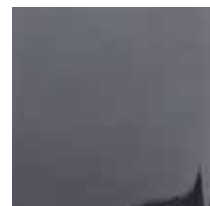

Glossy black Wood

La componentistica è in inox laccato nero opaco o nero lucido, segue la finitura del prodotto.  
Metal components are matt or glossy black lacquered, depending on the item finish.



100.005  
Divano 3 Posti 3-seater sofa



100.006  
Letino Sun lounger

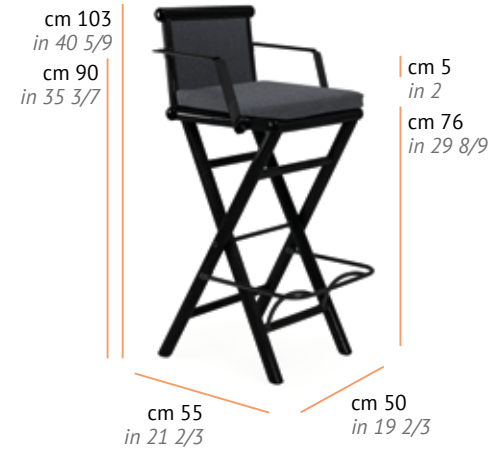

100.001  
Sgabello Barstool

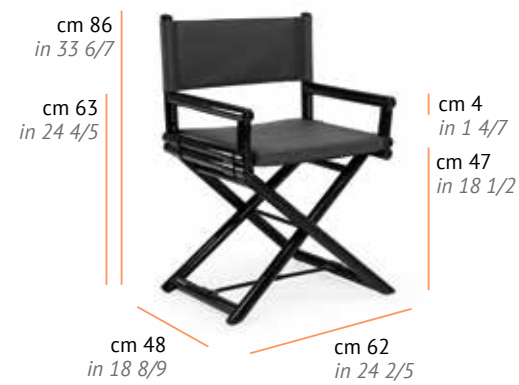

100.002  
Sedia richiudibile Director chair

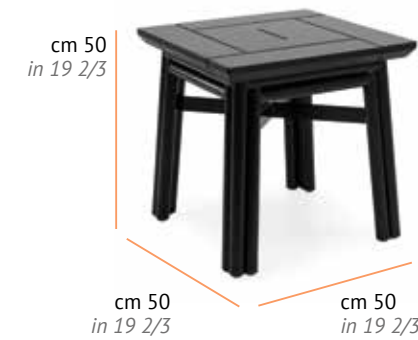

100.007  
Tavolino d'appoggio Side table



100.008  
Tavolino d'appoggio grande Big side table

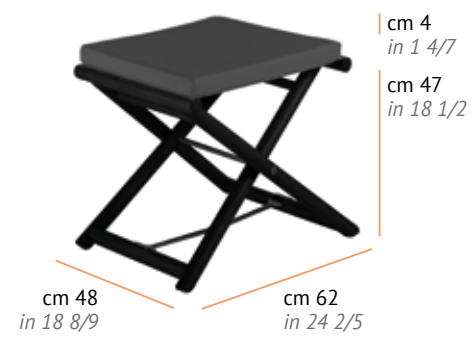

100.003  
Pouff Ottoman



100.004  
Poltrona Armchair



100.009  
Tavolino salotto Coffee table



100.010  
Tavolo pranzo quadrato Square dining table

**Maxim Plus**



**100.011**  
Tavolo pranzo tondo *Round dining table*



**100.012**  
Tavolo pranzo rettangolare *Rectangular dining table*

**Melania**

**Colori disponibili**  
*Available colors*



Off White

204

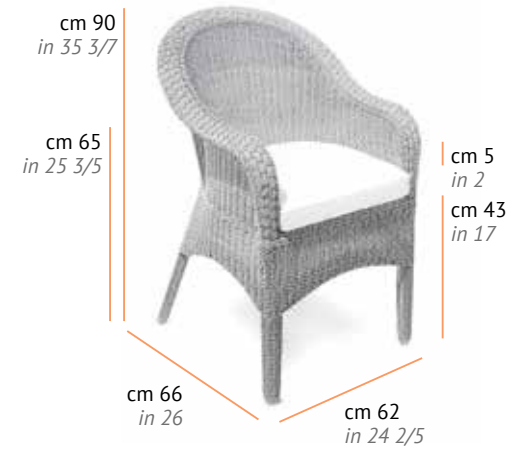

**106.001**  
Poltroncina pranzo *Dining armchair*

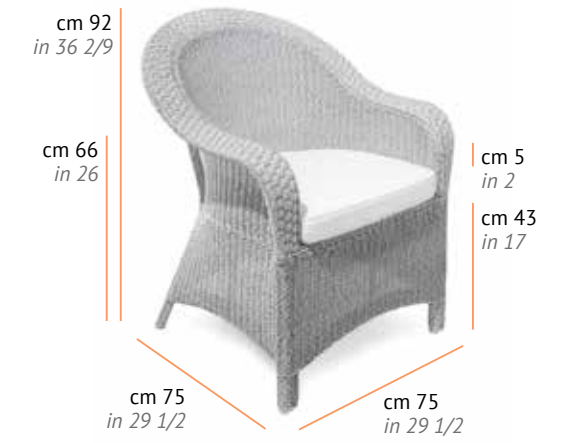

**106.002**  
Poltrona *Armchair*

205

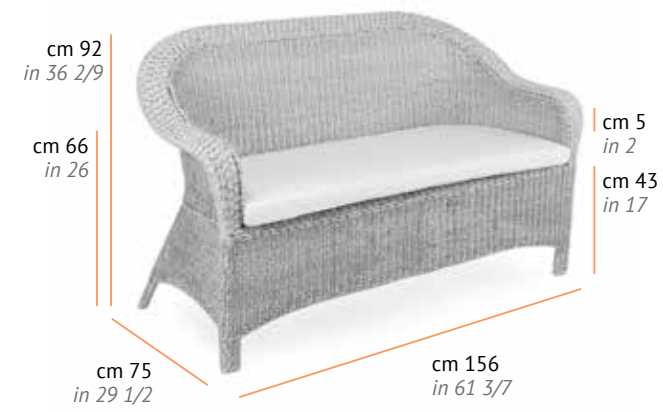

**106.003**  
Divano 2 Posti *2-seater sofa*

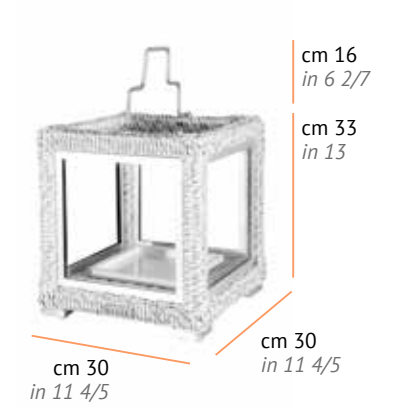

**106.009**  
Lanterna piccola *Small lantern*



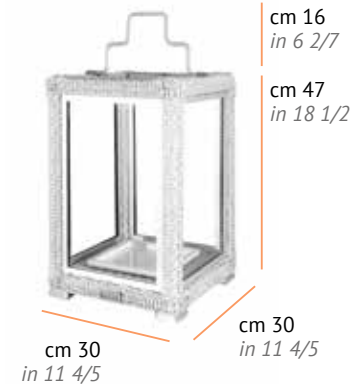

106.010  
Lanterna media *Medium lantern*



106.011  
Lanterna grande *Big lantern*

Colori disponibili  
*Available colors*

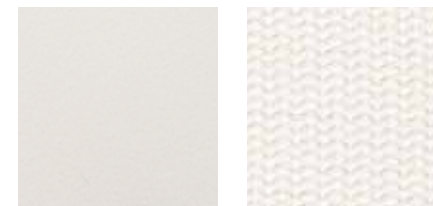

Ice Aluminum White Polyester

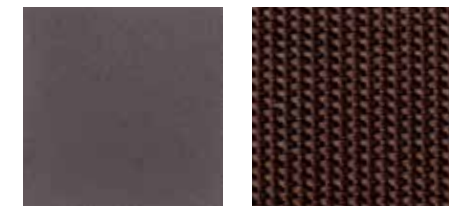

Taupe Aluminum Taupe Polyester

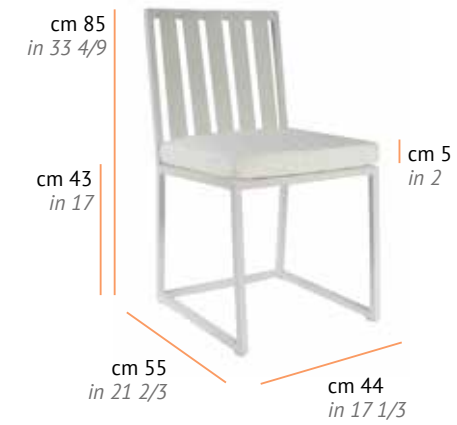

104.001  
Sedia *Dining chair*

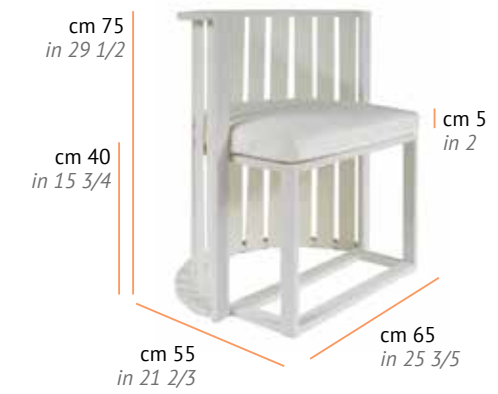

104.002  
Poltroncina pranzo *Dining armchair*

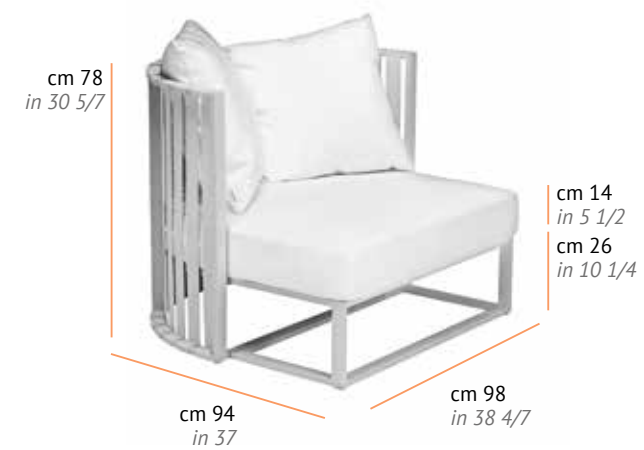

104.003  
Poltrona *Armchair*



104.004  
Divano 2 Posti *2-seater sofa*

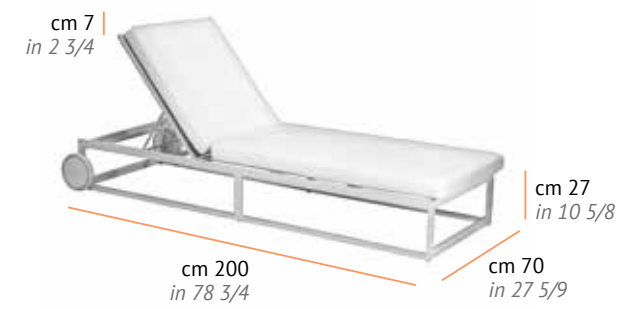

104.005  
Letino Sun lounger

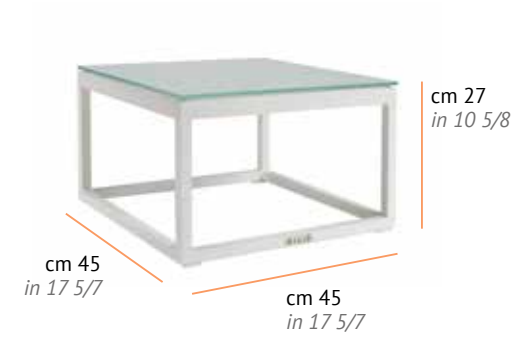

104.006  
Tavolino d'appoggio Side table



104.011  
Elemento centrale Central section



104.012  
Pouff Ottoman

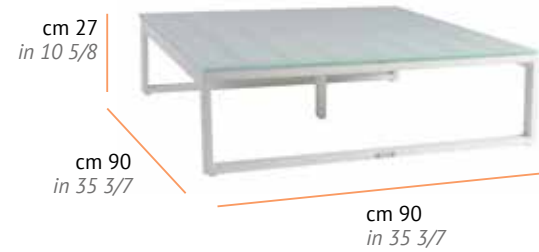

104.007  
Tavolino salotto Coffee table



104.008  
Tavolo pranzo allungabile Extendable dining table



104.009  
Angolo sinistro Left corner



104.010  
Angolo destro Right corner

**Metropolitan Gold**

**Colori disponibili**  
Available colors

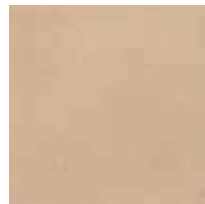

Gold Aluminum

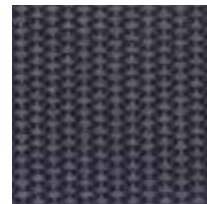

Black Polyester

**Metropolitan Gold**



**104.005**  
**Lettino Sun lounger**



**104.006**  
**Tavolino d'appoggio Side table**

210



**104.001**  
**Sedia Dining chair**

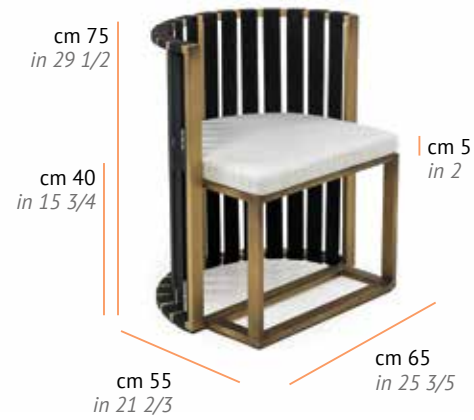

**104.002**  
**Poltroncina pranzo Dining armchair**

211



**104.007**  
**Tavolino salotto Coffee table**



**104.008**  
**Tavolo pranzo allungabile Extendable dining table**



**104.003**  
**Poltrona Armchair**



**104.004**  
**Divano 2 Posti 2-seater sofa**



**104.009**  
**Angolo sinistro Left corner**



**104.010**  
**Angolo destro Right corner**

**Metropolitan Gold**



104.011  
Elemento centrale *Central section*



104.012  
Pouff *Ottoman*

**Mood**

**Colori disponibili**  
*Available colors*



Shimmer



Taupe Aluminum



103.001  
Sedia *Dining chair*

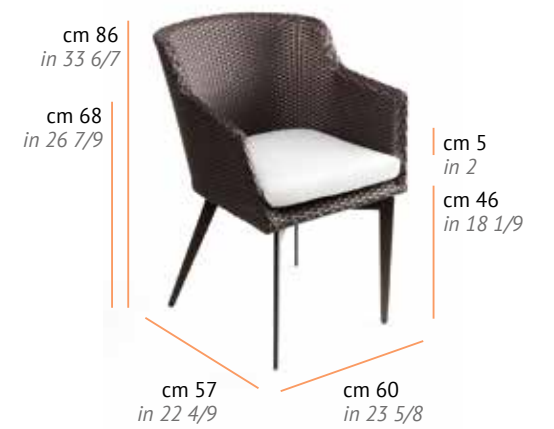

103.002  
Poltroncina pranzo *Dining armchair*



103.003  
Poltrona *Armchair*



103.004  
Divano 2 Posti *2-seater sofa*



103.005  
Lettino Sun lounger



103.006  
Tavolino d'appoggio Side table



103.011  
Angolo destro Right corner



103.012  
Elemento centrale Central section



103.007  
Tavolino salotto Coffee table

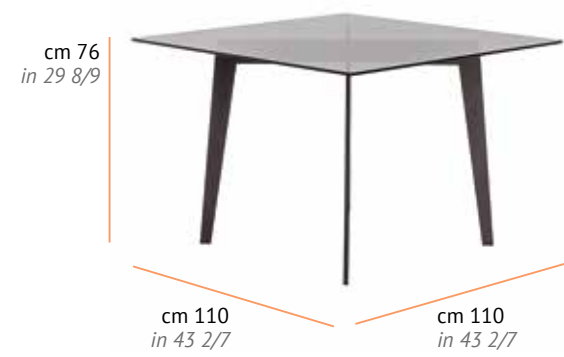

103.008  
Tavolo pranzo quadrato Square dining table



103.013  
Pouff Ottoman



103.009  
Tavolo pranzo rettangolare Rectangular dining table



103.010  
Angolo sinistro Left corner

Colori disponibili  
Available colors

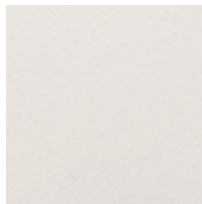

White Aluminum



Black Aluminum



102.005  
Lettino doppio *Double sun lounger*



102.006  
Tavolo d'appoggio *Side table*



102.001  
Poltrona *Armchair*



102.002  
Divano 2 Posti *2-seater sofa*



CB102.001  
Schienale grande per poltrona  
*Big armchair backrest cushion*



CS102.001  
Schienale piccolo per poltrona  
*Small armchair backrest cushion*



102.003  
Divano 3 Posti *3-seater sofa*



102.004  
Lettino singolo *Single sun lounger*



CB102.002  
Set 2 schienali grandi per divano 2 posti  
*Set of 2 big backrest cushions for 2-seater sofa*



CS102.002  
Set 2 schienali piccoli per divano 2 posti  
*Set of 2 small backrest cushions for 2-seater sofa*



CB102.003  
Set 3 schienali grandi per divano 3 posti  
Set of 3 big backrest cushions for 3-seater sofa

CS102.003  
Set 3 schienali piccoli per divano 3 posti  
Set of 3 small backrest cushions for 3-seater sofa

Colori disponibili  
Available colors



Silver dust

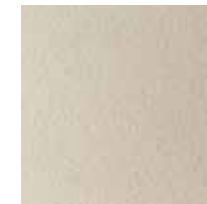

Champagne



101.001  
Poltrona Armchair



101.002  
Divano 2 Posti 2-seater sofa



101.003  
Divano 3 Posti 3-seater sofa

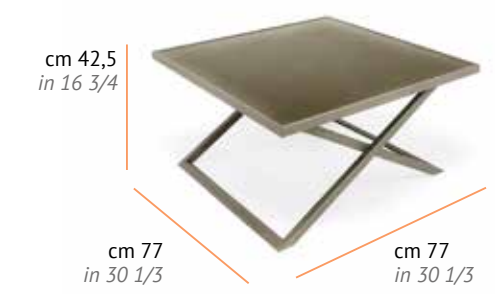

101.004  
Tavolino d'appoggio Side table

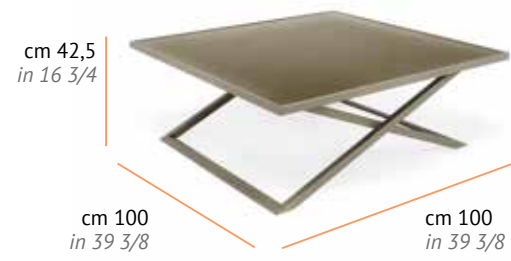

101.005  
Tavolino salotto *Coffee table*



101.006  
Lettino basso *Low sun lounger*



CB101.001  
Cuscino grande per poltrona *Big armchair cushion*



CS101.001  
Cuscino piccolo per poltrona *Small armchair cushion*



101.007  
Lettino alto *High sun lounger*



101.008  
Tavolino d'appoggio alto *High side table*



CB101.002  
Set 2 cuscini grandi per divano 2 posti  
*Set of 2 big cushions for 2-seater sofa*



CS101.002  
Set 2 cuscini piccoli per divano 2 posti  
*Set of 2 small cushions for 2-seater sofa*



101.009  
Tavolino d'appoggio basso *Low side table*



CB101.003  
Set 3 cuscini grandi per divano 3 posti  
*Set of 3 big cushions for 3-seater sofa*



CS101.003  
Set 3 cuscini piccoli per divano 3 posti  
*Set of 3 small cushions for 3-seater sofa*



**Colori disponibili**  
Available colors



Black + Bamboo handle    Black + Black metal handle    Gold + Black bamboo handle    Gold + Gold metal handle

**Colori disponibili**  
Available colors

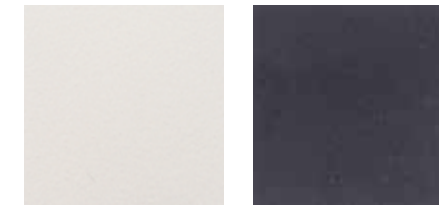

White    Black

I tessuti degli ombrelloni sono disponibili nei colori White, Taupe e Black.  
*Outdoor umbrella fabrics are available in White, Taupe, and Black.*

Il peso della zavorra sulla base deve essere proporzionato al peso dell'ombrellone.  
Se ne consiglia l'uso in condizioni meteorologiche normali.  
*The weight of the base must be proportional to the weight of the umbrella. Its usage is recommended in normal weather conditions.*

222



**110.001**  
Lanterna grande *Big lantern*



**110.002**  
Lanterna media *Medium lantern*



**110.003**  
Lanterna piccola *Small lantern*

223



**111.001**  
Ombrellone 3x3m palo centrale  
*Center-pole umbrella (in 118 1/9 x in 118 1/9)*



**111.002**  
Ombrellone 2,8x2,8m  
*Side-arm umbrella (in 110 1/4 x in 110 1/4)*



**111.002**



**111.002**



**111.003**  
**Ombrellone 3x4m braccio laterale**  
*Side-arm umbrella (in 118 1/9 x in 157 1/2)*

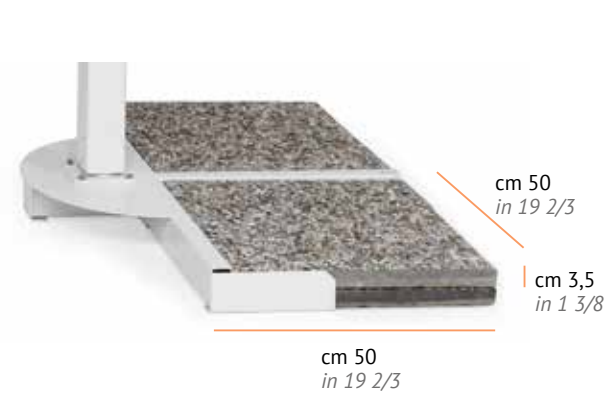

**B111.002**  
**Kit 6 Zavorre (peso 21kg cadauno)**  
*Kit of 6 base weights (46,3 Lbs each)*

**B111.003**  
**Kit 8 Zavorre (peso 21kg cadauno)**  
*Kit of 8 base weights (46,3 Lbs each)*

**Colori disponibili**  
*Available colors*

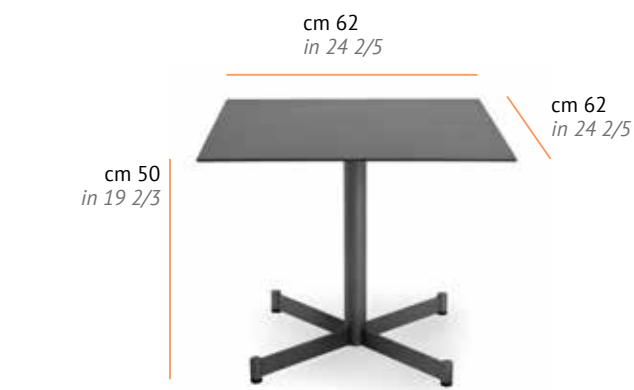

**109.001**  
**Tavolo appoggio quadrato** *Square side table*



**109.002**  
**Tavolo appoggio rotondo** *Round side table*



**109.003**  
**Tavolo da fumo ovale** *Oval side table*

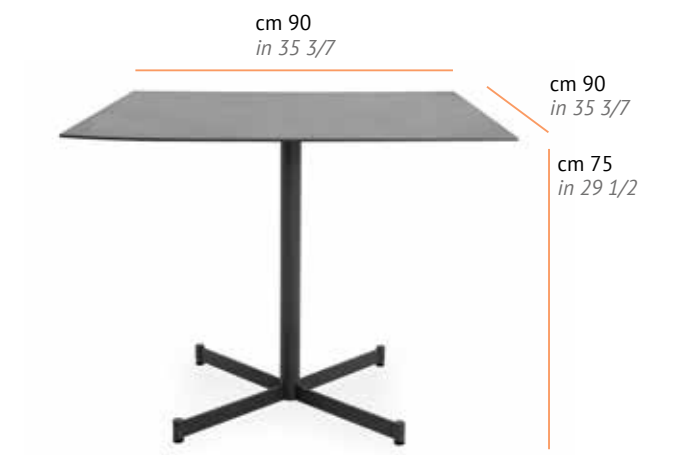

**109.004**  
**Tavolo pranzo quadrato** *Square dining table*

**Teodora**



109.005  
Tavolo pranzo rotondo *Round dining table*

**Raissa**

**Colori disponibili**  
*Available colors*

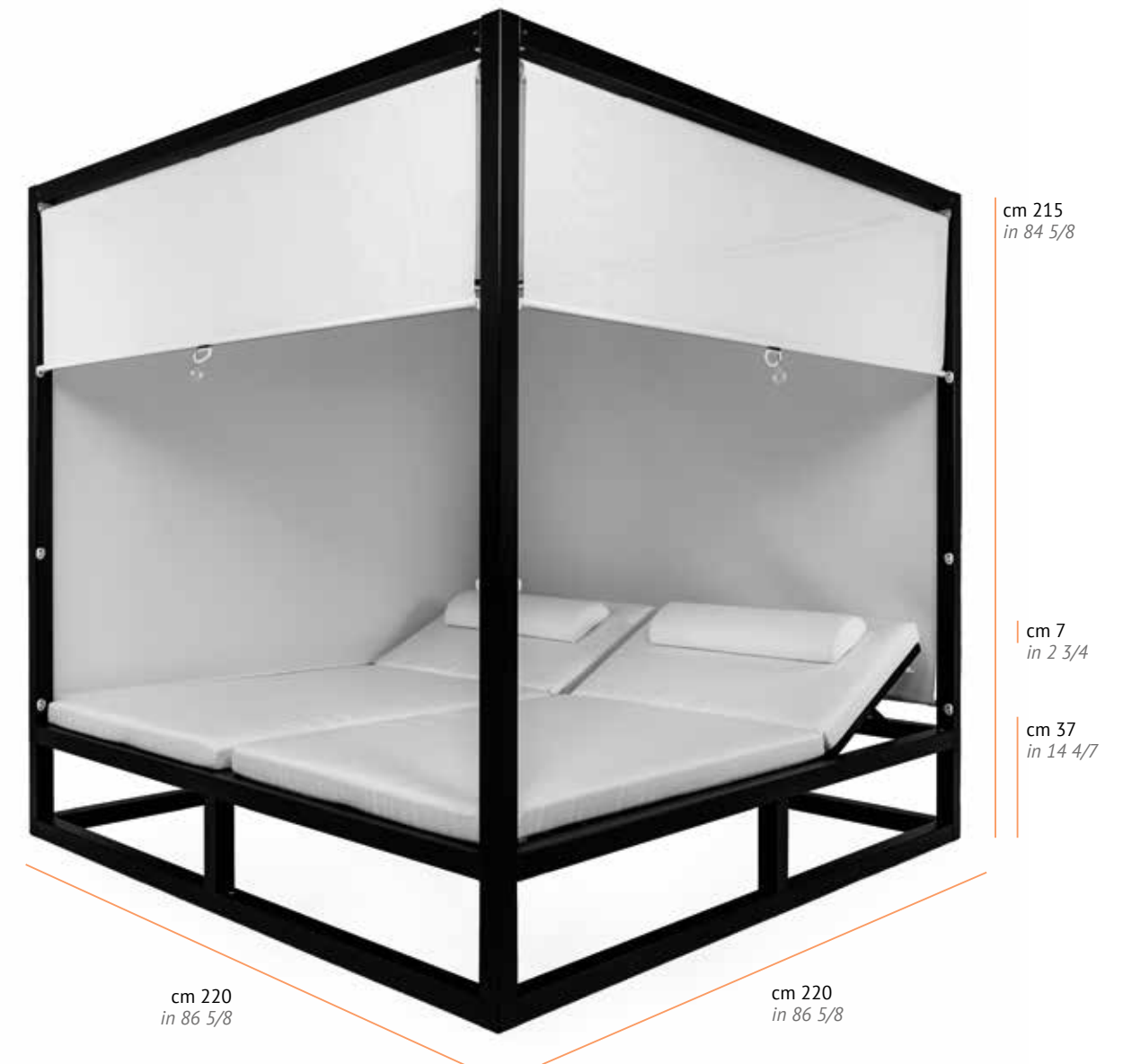
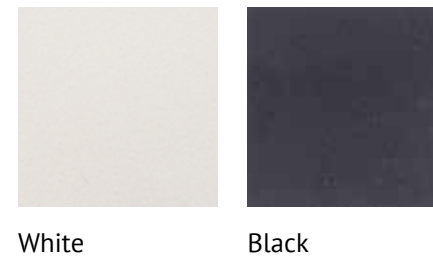

112.001  
Cabana comprensiva di celino richiudibile  
e tende in tessuto bianco perimetrali chiudibili a rullo  
*Outdoor cabana with retractable roof shade and four-side  
roll-down shades in white fabric*

# **Cuscini** *Cushions*



Cuscini Cushions

60x60 cm = 23 5/8 x 23 5/8 inches  
 50x50 cm = 19 2/3 x 19 2/3 inches

Cuscini Cushions



<u>C199.001.001</u> 50x50 cm	<u>C199.001.003</u> 50x50 cm	<u>C199.001.005</u> 50x50 cm	<u>C199.001.007</u> 50x50 cm	<u>C199.001.009</u> 50x50 cm
<u>C199.001.002</u> 60x60 cm	<u>C199.001.004</u> 60x60 cm	<u>C199.001.006</u> 60x60 cm	<u>C199.001.008</u> 60x60 cm	<u>C199.001.010</u> 60x60 cm
Tessuto Fabric 1001	Tessuto Fabric 1002	Tessuto Fabric 1003	Tessuto Fabric 1004	Tessuto Fabric 1005



<u>C199.001.031</u> 50x50 cm	<u>C199.001.033</u> 50x50 cm	<u>C199.001.035</u> 50x50 cm	<u>C199.001.037</u> 50x50 cm	<u>C199.001.039</u> 50x50 cm
<u>C199.001.032</u> 60x60 cm	<u>C199.001.034</u> 60x60 cm	<u>C199.001.036</u> 60x60 cm	<u>C199.001.038</u> 60x60 cm	<u>C199.001.040</u> 60x60 cm
Tessuto Fabric 1016	Tessuto Fabric 1017	Tessuto Fabric 1018	Tessuto Fabric 1019	Tessuto Fabric 1020

230



<u>C199.001.011</u> 50x50 cm	<u>C199.001.013</u> 50x50 cm	<u>C199.001.015</u> 50x50 cm	<u>C199.001.017</u> 50x50 cm	<u>C199.001.019</u> 50x50 cm
<u>C199.001.012</u> 60x60 cm	<u>C199.001.014</u> 60x60 cm	<u>C199.001.016</u> 60x60 cm	<u>C199.001.018</u> 60x60 cm	<u>C199.001.020</u> 60x60 cm
Tessuto Fabric 1006	Tessuto Fabric 1007	Tessuto Fabric 1008	Tessuto Fabric 1009	Tessuto Fabric 1010



<u>C199.001.041</u> 50x50 cm	<u>C199.001.045</u> 50x50 cm	<u>C199.001.047</u> 50x50 cm	<u>C199.001.049</u> 50x50 cm	<u>C199.001.051</u> 50x50 cm
<u>C199.001.042</u> 60x60 cm	<u>C199.001.046</u> 60x60 cm	<u>C199.001.048</u> 60x60 cm	<u>C199.001.050</u> 60x60 cm	<u>C199.001.052</u> 60x60 cm
Tessuto Fabric 1021	Tessuto Fabric 1023	Tessuto Fabric 1024	Tessuto Fabric 1025	Tessuto Fabric 1026

231



<u>C199.001.021</u> 50x50 cm	<u>C199.001.023</u> 50x50 cm	<u>C199.001.025</u> 50x50 cm	<u>C199.001.027</u> 50x50 cm	<u>C199.001.029</u> 50x50 cm
<u>C199.001.022</u> 60x60 cm	<u>C199.001.024</u> 60x60 cm	<u>C199.001.026</u> 60x60 cm	<u>C199.001.028</u> 60x60 cm	<u>C199.001.030</u> 60x60 cm
Tessuto Fabric 1011	Tessuto Fabric 1012	Tessuto Fabric 1013	Tessuto Fabric 1014	Tessuto Fabric 1015



<u>C199.001.053</u> 50x50 cm	<u>C199.001.055</u> 50x50 cm	<u>C199.001.057</u> 50x50 cm	<u>C199.001.059</u> 50x50 cm	<u>C199.001.061</u> 50x50 cm
<u>C199.001.054</u> 60x60 cm	<u>C199.001.056</u> 60x60 cm	<u>C199.001.058</u> 60x60 cm	<u>C199.001.060</u> 60x60 cm	<u>C199.001.062</u> 60x60 cm
Tessuto Fabric 1027	Tessuto Fabric 1028	Tessuto Fabric 1029	Tessuto Fabric 1030	Tessuto Fabric 1031



<u>C199.001.063</u> 50x50 cm	<u>C199.001.071</u> 50x50 cm	<u>C199.001.073</u> 50x50 cm	<u>C199.001.075</u> 50x50 cm	<u>C199.001.077</u> 50x50 cm
<u>C199.001.064</u> 60x60 cm	<u>C199.001.072</u> 60x60 cm	<u>C199.001.074</u> 60x60 cm	<u>C199.001.076</u> 60x60 cm	<u>C199.001.078</u> 60x60 cm
Tessuto Fabric 1032	Tessuto Fabric 1039	Tessuto Fabric 1041	Tessuto Fabric 1035	Tessuto Fabric 1036



<u>C199.001.079</u> 50x50 cm	<u>C199.001.081</u> 50x50 cm	<u>C199.001.083</u> 50x50 cm	<u>C199.001.085</u> 50x50 cm	<u>C199.001.087</u> 50x50 cm
<u>C199.001.080</u> 60x60 cm	<u>C199.001.082</u> 60x60 cm	<u>C199.001.084</u> 60x60 cm	<u>C199.001.086</u> 60x60 cm	<u>C199.001.088</u> 60x60 cm
Tessuto Fabric 1037	Tessuto Fabric 1038	Tessuto Fabric 1040	Tessuto Fabric 1042	Tessuto Fabric 1043



<u>C199.001.089</u> 50x50 cm	<u>C199.001.091</u> 50x50 cm	<u>C199.001.093</u> 50x50 cm	<u>C199.001.095</u> 50x50 cm
<u>C199.001.090</u> 60x60 cm	<u>C199.001.092</u> 60x60 cm	<u>C199.001.094</u> 60x60 cm	<u>C199.001.096</u> 60x60 cm
Tessuto Fabric 1044	Tessuto Fabric 1045	Pelle Leather 1201	Pelle Leather 1202



<u>C199.002.001</u> 50x50 cm	<u>C199.002.003</u> 50x50 cm	<u>C199.002.005</u> 50x50 cm	<u>C199.002.007</u> 50x50 cm	<u>C199.002.009</u> 50x50 cm
<u>C199.002.002</u> 60x60 cm	<u>C199.002.004</u> 60x60 cm	<u>C199.002.006</u> 60x60 cm	<u>C199.002.008</u> 60x60 cm	<u>C199.002.010</u> 60x60 cm
Tessuto Fabric 1001,1005	Tessuto Fabric 1001,1003	Tessuto Fabric 1001,1008	Tessuto Fabric 1001,1010	Tessuto Fabric 1001,1018



<u>C199.002.011</u> 50x50 cm	<u>C199.002.013</u> 50x50 cm	<u>C199.002.015</u> 50x50 cm	<u>C199.002.017</u> 50x50 cm	<u>C199.002.019</u> 50x50 cm
<u>C199.002.012</u> 60x60 cm	<u>C199.002.014</u> 60x60 cm	<u>C199.002.016</u> 60x60 cm	<u>C199.002.018</u> 60x60 cm	<u>C199.002.020</u> 60x60 cm
Tessuto Fabric 1001,1009	Tessuto Fabric 1001,1014	Tessuto Fabric 1001,1012	Tessuto Fabric 1001,1013	Tessuto Fabric 1001,1016



<u>C199.002.021</u> 50x50 cm	<u>C199.002.023</u> 50x50 cm	<u>C199.002.025</u> 50x50 cm	<u>C199.002.027</u> 50x50 cm	<u>C199.002.029</u> 50x50 cm
<u>C199.002.022</u> 60x60 cm	<u>C199.002.024</u> 60x60 cm	<u>C199.002.026</u> 60x60 cm	<u>C199.002.028</u> 60x60 cm	<u>C199.002.030</u> 60x60 cm
Tessuto Fabric 1001,1019	Tessuto Fabric 1001,1023	Tessuto Fabric 1002,1005	Tessuto Fabric 1002,1003	Tessuto Fabric 1002,1008



<u>C199.002.031</u> 50x50 cm Tessuto <i>Fabric</i> 1002,1010	<u>C199.002.033</u> 50x50 cm Tessuto <i>Fabric</i> 1002,1018	<u>C199.002.035</u> 50x50 cm Tessuto <i>Fabric</i> 1002,1009	<u>C199.002.037</u> 50x50 cm Tessuto <i>Fabric</i> 1002,1014	<u>C199.002.039</u> 50x50 cm Tessuto <i>Fabric</i> 1002,1012
<u>C199.002.032</u> 60x60 cm	<u>C199.002.034</u> 60x60 cm	<u>C199.002.036</u> 60x60 cm	<u>C199.002.038</u> 60x60 cm	<u>C199.002.040</u> 60x60 cm



<u>C199.002.041</u> 50x50 cm Tessuto <i>Fabric</i> 1002,1013	<u>C199.002.043</u> 50x50 cm Tessuto <i>Fabric</i> 1002,1016	<u>C199.002.045</u> 50x50 cm Tessuto <i>Fabric</i> 1002,1019	<u>C199.002.047</u> 50x50 cm Tessuto <i>Fabric</i> 1002,1023	<u>C199.002.049</u> 50x50 cm Tessuto <i>Fabric</i> 1018,1019
<u>C199.002.042</u> 60x60 cm	<u>C199.002.044</u> 60x60 cm	<u>C199.002.046</u> 60x60 cm	<u>C199.002.048</u> 60x60 cm	<u>C199.002.050</u> 60x60 cm



<u>C199.002.051</u> 50x50 cm Tessuto <i>Fabric</i> 1013,1014	<u>C199.002.053</u> 50x50 cm Tessuto <i>Fabric</i> 1009,1007	<u>C199.002.055</u> 50x50 cm Tessuto <i>Fabric</i> 1019,1010	<u>C199.002.057</u> 50x50 cm Tessuto <i>Fabric</i> 1003,1017
<u>C199.002.052</u> 60x60 cm	<u>C199.002.054</u> 60x60 cm	<u>C199.002.056</u> 60x60 cm	<u>C199.002.058</u> 60x60 cm



<u>C199.003.001</u> 50x50 cm Tessuto <i>Fabric</i> 1001,1005	<u>C199.003.003</u> 50x50 cm Tessuto <i>Fabric</i> 1001,1003	<u>C199.003.005</u> 50x50 cm Tessuto <i>Fabric</i> 1001,1008	<u>C199.003.007</u> 50x50 cm Tessuto <i>Fabric</i> 1001,1010	<u>C199.003.009</u> 50x50 cm Tessuto <i>Fabric</i> 1001,1018
<u>C199.003.002</u> 60x60 cm	<u>C199.003.004</u> 60x60 cm	<u>C199.003.006</u> 60x60 cm	<u>C199.003.008</u> 60x60 cm	<u>C199.003.010</u> 60x60 cm



<u>C199.003.011</u> 50x50 cm Tessuto <i>Fabric</i> 1001,1009	<u>C199.003.013</u> 50x50 cm Tessuto <i>Fabric</i> 1001,1014	<u>C199.003.015</u> 50x50 cm Tessuto <i>Fabric</i> 1001,1012	<u>C199.003.017</u> 50x50 cm Tessuto <i>Fabric</i> 1001,1013	<u>C199.003.019</u> 50x50 cm Tessuto <i>Fabric</i> 1001,1016
<u>C199.003.012</u> 60x60 cm	<u>C199.003.014</u> 60x60 cm	<u>C199.003.016</u> 60x60 cm	<u>C199.003.018</u> 60x60 cm	<u>C199.003.020</u> 60x60 cm



<u>C199.003.021</u> 50x50 cm Tessuto <i>Fabric</i> 1001,1019	<u>C199.003.023</u> 50x50 cm Tessuto <i>Fabric</i> 1001,1023	<u>C199.003.025</u> 50x50 cm Tessuto <i>Fabric</i> 1002,1005	<u>C199.003.027</u> 50x50 cm Tessuto <i>Fabric</i> 1002,1003	<u>C199.003.029</u> 50x50 cm Tessuto <i>Fabric</i> 1002,1008
<u>C199.003.022</u> 60x60 cm	<u>C199.003.024</u> 60x60 cm	<u>C199.003.026</u> 60x60 cm	<u>C199.003.028</u> 60x60 cm	<u>C199.003.030</u> 60x60 cm



<u>C199.003.031</u> 50x50 cm Tessuto <i>Fabric</i> 1002, 1010	<u>C199.003.033</u> 50x50 cm Tessuto <i>Fabric</i> 1002, 1018	<u>C199.003.035</u> 50x50 cm Tessuto <i>Fabric</i> 1002, 1009	<u>C199.003.037</u> 50x50 cm Tessuto <i>Fabric</i> 1002, 1014	<u>C199.003.039</u> 50x50 cm Tessuto <i>Fabric</i> 1002, 1012
<u>C199.003.032</u> 60x60 cm Tessuto <i>Fabric</i> 1002, 1010	<u>C199.003.034</u> 60x60 cm Tessuto <i>Fabric</i> 1002, 1018	<u>C199.003.036</u> 60x60 cm Tessuto <i>Fabric</i> 1002, 1009	<u>C199.003.038</u> 60x60 cm Tessuto <i>Fabric</i> 1002, 1014	<u>C199.003.040</u> 60x60 cm Tessuto <i>Fabric</i> 1002, 1012



<u>C199.003.041</u> 50x50 cm Tessuto <i>Fabric</i> 1002, 1013	<u>C199.003.043</u> 50x50 cm Tessuto <i>Fabric</i> 1002, 1016	<u>C199.003.045</u> 50x50 cm Tessuto <i>Fabric</i> 1002, 1019	<u>C199.003.047</u> 50x50 cm Tessuto <i>Fabric</i> 1002, 1023
<u>C199.003.042</u> 60x60 cm Tessuto <i>Fabric</i> 1002, 1013	<u>C199.003.044</u> 60x60 cm Tessuto <i>Fabric</i> 1002, 1016	<u>C199.003.046</u> 60x60 cm Tessuto <i>Fabric</i> 1002, 1019	<u>C199.003.048</u> 60x60 cm Tessuto <i>Fabric</i> 1002, 1023



<u>C199.004.001</u> 50x50 cm Tess. <i>Fabric</i> 1018, 1002, 1019	<u>C199.004.002</u> 50x50 cm Tess. <i>Fabric</i> 1013, 1002, 1014	<u>C199.004.003</u> 50x50 cm Tess. <i>Fabric</i> 1007, 1002, 1009	<u>C199.004.004</u> 50x50 cm Tess. <i>Fabric</i> 1019, 1002, 1010	<u>C199.004.005</u> 50x50 cm Tess. <i>Fabric</i> 1003, 1002, 1017
---	---	---	---	---



<u>C199.005.001</u> 30x60 cm Tessuto <i>Fabric</i> 1001, 1005	<u>C199.005.002</u> 30x60 cm Tessuto <i>Fabric</i> 1001, 1003	<u>C199.005.003</u> 30x60 cm Tessuto <i>Fabric</i> 1001, 1008	<u>C199.005.004</u> 30x60 cm Tessuto <i>Fabric</i> 1001, 1010	<u>C199.005.005</u> 30x60 cm Tessuto <i>Fabric</i> 1001, 1018
---	---	---	---	---



<u>C199.005.006</u> 30x60 cm Tessuto <i>Fabric</i> 1001, 1009	<u>C199.005.007</u> 30x60 cm Tessuto <i>Fabric</i> 1001, 1014	<u>C199.005.008</u> 30x60 cm Tessuto <i>Fabric</i> 1001, 1012	<u>C199.005.009</u> 30x60 cm Tessuto <i>Fabric</i> 1001, 1013	<u>C199.005.010</u> 30x60 cm Tessuto <i>Fabric</i> 1001, 1016
---	---	---	---	---



<u>C199.005.011</u> 30x60 cm Tessuto <i>Fabric</i> 1001, 1019	<u>C199.005.012</u> 30x60 cm Tessuto <i>Fabric</i> 1001, 1023	<u>C199.005.013</u> 30x60 cm Tessuto <i>Fabric</i> 1002, 1005	<u>C199.005.014</u> 30x60 cm Tessuto <i>Fabric</i> 1002, 1003	<u>C199.005.015</u> 30x60 cm Tessuto <i>Fabric</i> 1002, 1008
---	---	---	---	---



Cuscini *Cushions*



C199.005.016

30x60 cm

Tessuto *Fabric* 1002, 1010

C199.005.017

30x60 cm

Tessuto *Fabric* 1002, 1018

C199.005.018

30x60 cm

Tessuto *Fabric* 1002, 1009

C199.005.019

30x60 cm

Tessuto *Fabric* 1002, 1014

C199.005.020

30x60 cm

Tessuto *Fabric* 1002, 1012



C199.005.021

30x60 cm

Tessuto *Fabric* 1002, 1013

C199.005.022

30x60 cm

Tessuto *Fabric* 1002, 1016

C199.005.023

30x60 cm

Tessuto *Fabric* 1002, 1019

C199.005.024

30x60 cm

Tessuto *Fabric* 1002, 1023

# Tessuti e materiali

## *Fabrics & Materials*



# Solids



1001 / Cat. A    1002 / Cat. A    1003 / Cat. B    1004 / Cat. B



1005 / Cat. B    1006 / Cat. B    1007 / Cat. B    1008 / Cat. B

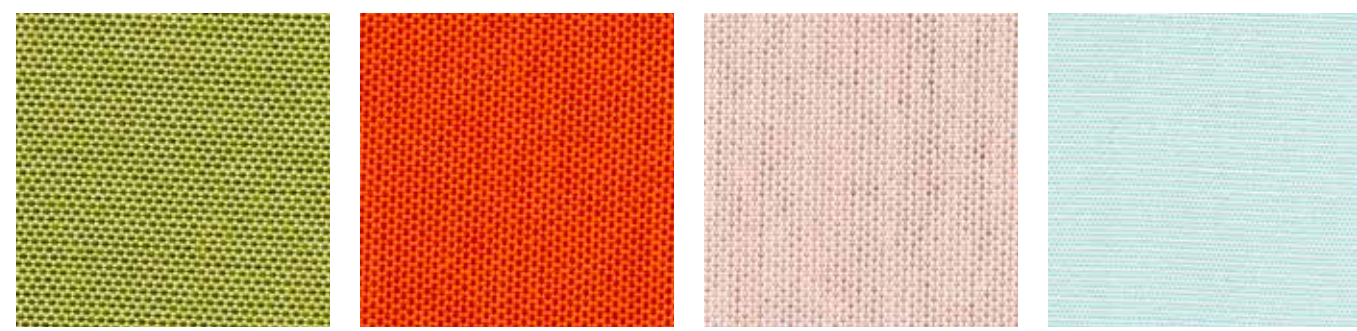

1009 / Cat. B    1010 / Cat. B    1011 / Cat. B    1012 / Cat. B

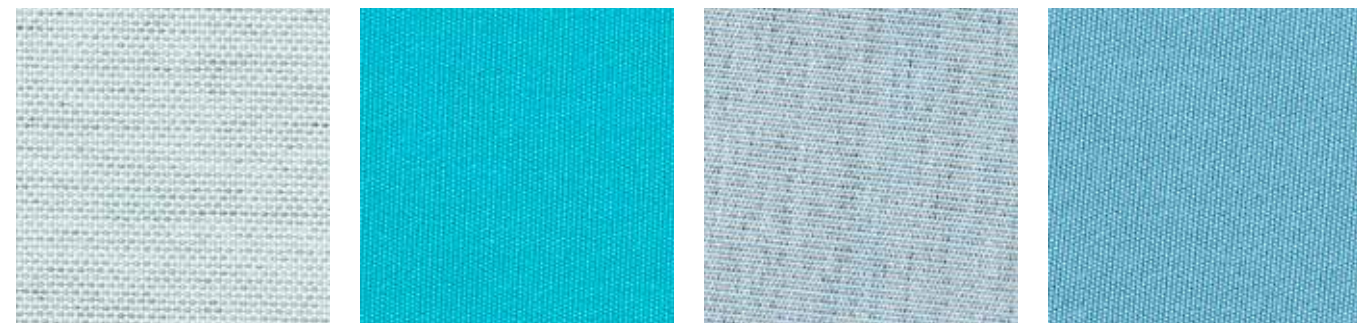

1013 / Cat. B    1014 / Cat. B    1015 / Cat. B    1016 / Cat. B

240



1017 / Cat. B    1018 / Cat. B    1019 / Cat. B

# Nattè

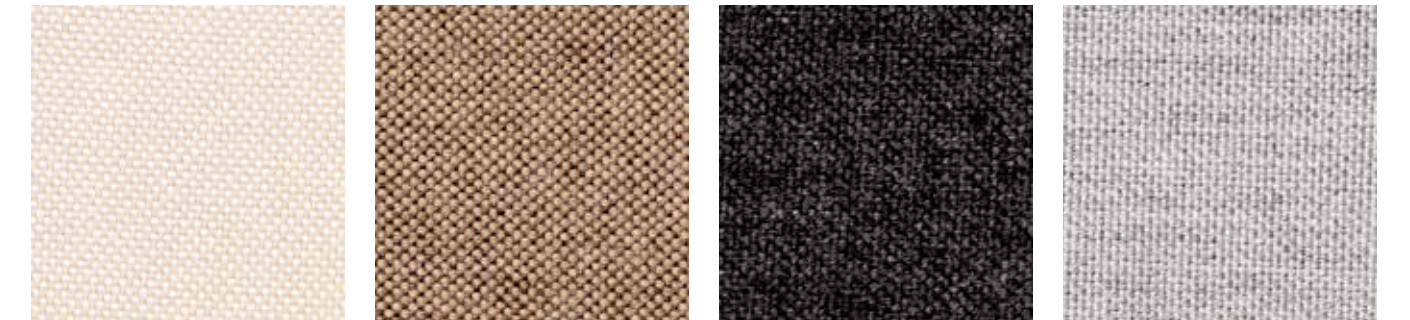

1020 / Cat. B    1021 / Cat. B    1023 / Cat. B    1024 / Cat. B

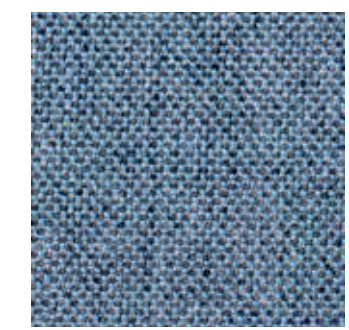

1025 / Cat. B

241

# Lopi



1026 / Cat. C

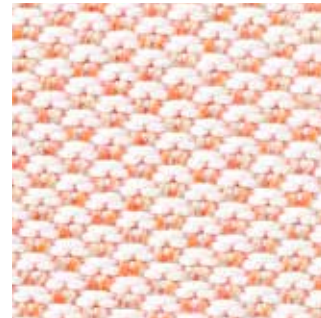

1027 / Cat. C

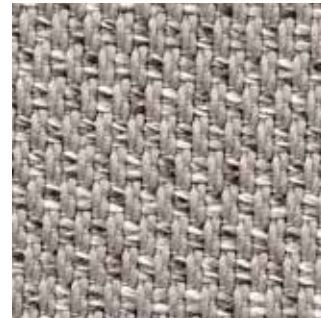

1028 / Cat. C



1029 / Cat. C

# Mosaic



1030 / Cat. C



1031 / Cat. C



1032 / Cat. C

# Sand impermeabile



1033 / Cat. A  
For protection cover only

# Solids



1035 / Cat. D

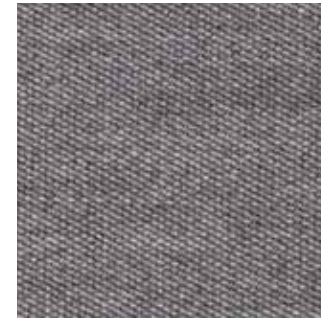

1036 / Cat. D



1037 / Cat. D



1038 / Cat. D



1039 / Cat. D

# Stripes



1040 / Cat. D



1041 / Cat. D



1042 / Cat. D



1043 / Cat. D



1044 / Cat. D



1045 / Cat. D

## Pelle *Leather*



1201 / Cat. Extra



1202 / Cat. Extra

## BATYLINE® Maxim collection



1051 / Cat. B

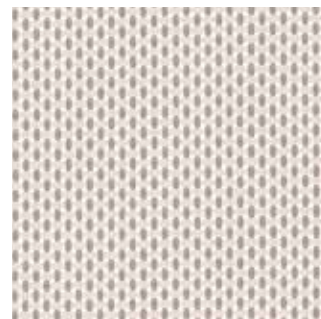

1052 / Cat. B

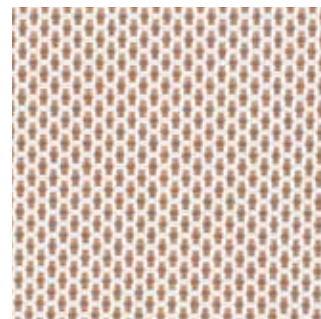

1053 / Cat. B



1054 / Cat. B



1055 / Cat. B

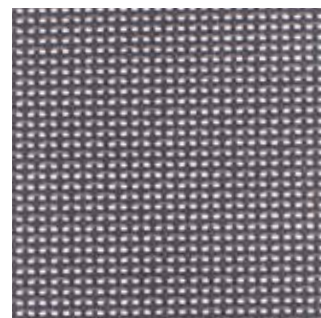

1056 / Cat. B

244

## Alluminio *Aluminum*

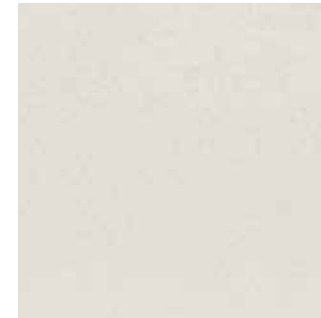

Ice



Taupe



Champagne

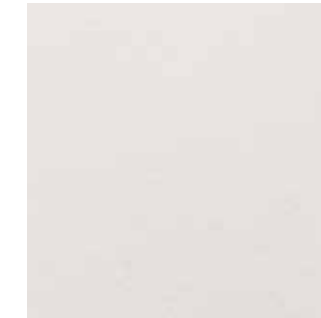

White



Grey



Black

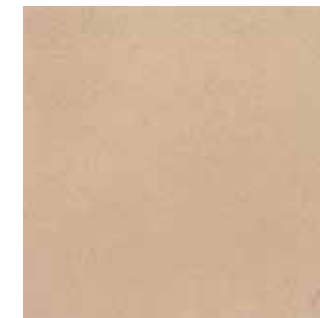

Gold

245

## Poliestere *Polyester*

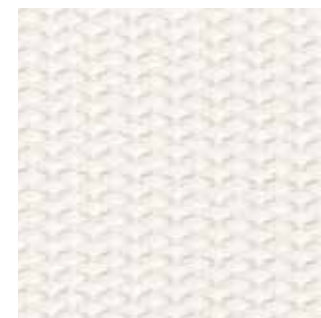

White Polyester stripe

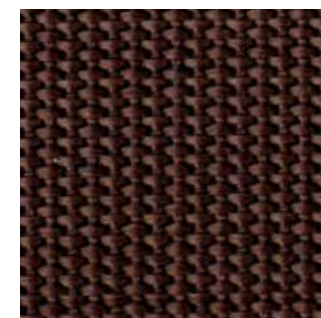

Taupe Polyester stripe

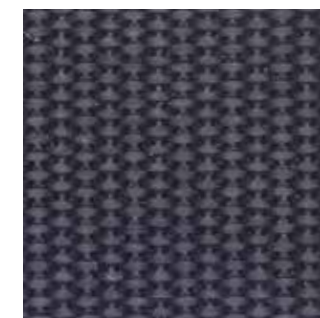

Black Polyester stripe

**LAMINAM**<sup>®</sup>

**Intrecci Woven**



Fokos Terra II



Oxide Nero II



Ossidiana vena scura

**Vetro Glass**



White Glass



Taupe Glass

**Legno Wood**



Natural Wood



Glossy Wood



Matt black Wood

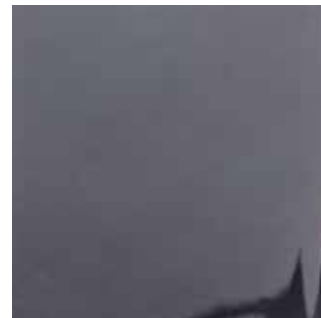

Glossy black Wood

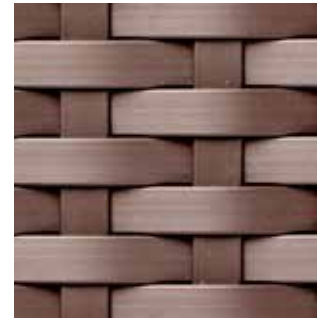

Shimmer



Silver Dust



Off White

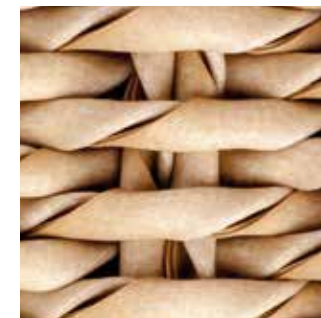

Euro Ash

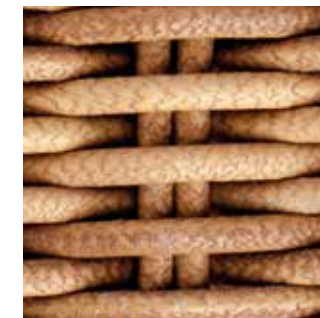

Natural

Art Direction  
*Andrea Barchiesi*

Graphic design  
*Tadao Studio*

Photos  
*Andrea Barchiesi*  
*Stefano Nardi (still life pictures)*

Styling and Set design  
*Alessandra Orlandi*

Print  
*Tipografia Luce - Osimo*

Thanks to  
*Masseria Le Torri - Polignano a mare (BA)*  
*Masseria San Francesco - Fasano (BR)*

Printed in December 2017

**braid**

**Braid Company Srl**  
Zona Ind.le Piani D'Ete, 34  
62010 Mogliano (MC)  
Italy

T +39 0733 556792 / 559006  
F +39 0733 1870105  
[www.braid.it](http://www.braid.it)  
[info@braid.it](mailto:info@braid.it)

